

Design & Control of an Outdoor Robotic Walker

Final Presentation – 4/12/2012

John Jagosztyn, Jonathan Lenoff, and Michael Bunne

Department of Mechanical Engineering, Florida State University, Tallahassee, FL

Project Sponsor:



Project Advisors:

Dr. Emmanuel G. Collins, Ph.D

Dr. Oscar Chuy, Ph.D

Department of Mechanical Engineering

Overview

- 1) Project Introduction**
- 2) Design Specifications**
- 3) Concept Generation**
- 4) Interim Designs**
- 5) Final Design**
- 6) Manufacturing & Assembly**
- 7) Testing & Results**
- 8) Discussion & Conclusions**

Problem Statement

The current generation of mobility assistive devices limits the user in freedom of motion and provides little additional assistance to the user beyond simple stabilization.

Current Generation Limitations:

- **Traversable terrain**
 - Indoor operation only
- **Functionality**
 - Only perform basic functions
- **Expensive or unnecessary**
 - Scooters / electric wheelchairs



<http://www.hizook.com/blog/2009/08/10/robotic-walkers-assist-elderly>



<http://www.4-medical-supplies.com/electric-power-wheelchairs>

Proposed Solution

Develop an assistive walking device designed to actively assist the user in both indoor and outdoor maneuverability.

Objectives:

- Further empower disabled & elderly
- Offer wide-range of assistive functions
- Maintain ease of use & intuitiveness

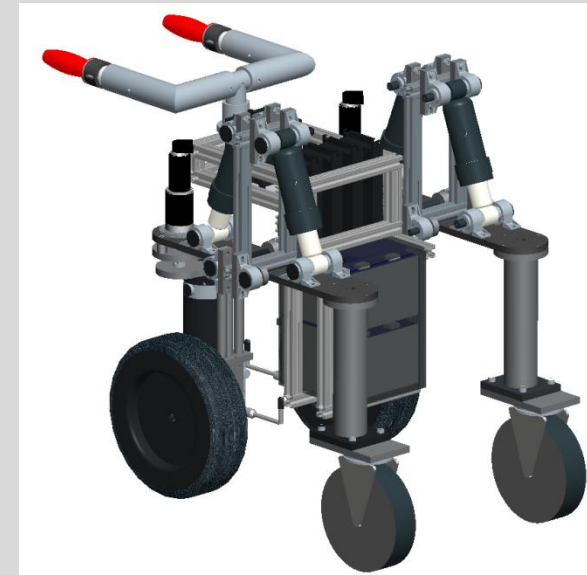

Proposed solution

Project Scope

Design and construct the initial research platform for a user-controlled outdoor robotic walker.

Project Constraints:

- **Traverse varied terrain surfaces**
 - Indoor: Tile, Carpet
 - Outdoor: Concrete, Grass, Gravel, Dirt
- **Operate within the Americans with Disabilities Act (ADA) standards**
- **Utilize force-based user controls**
- **Cost less than \$5000**
- **Allow for design evolution of future platforms in years to come**



Final assembly

- 1) Project Introduction**
- 2) Design Specifications**
- 3) Concept Generation**
- 4) Interim Designs**
- 5) Final Design**
- 6) Manufacturing & Assembly**
- 7) Testing & Results**
- 8) Discussion & Conclusions**

Specifications

Frame:

- **Aesthetics**
 - Resemble current generation of walkers
- **Dimensions**
 - Handle height – 32 to 39 inches
 - Handle width – 14 to 23 inches
- **Safety Standards**
 - Support up to 300 pounds
- **Light weight**
 - Less than 200 pounds
 - Aluminum framing



CAD of core frame

Specifications

Propulsion:

- **Minimum 11 inch diameter wheels or tracks**
- **Travel up / down slopes up to 10°**
- **Semi-omni-directional movement**
 - **Move transversely 45° from the center axis**
- **Maximum operating speed of at least 5 mph**

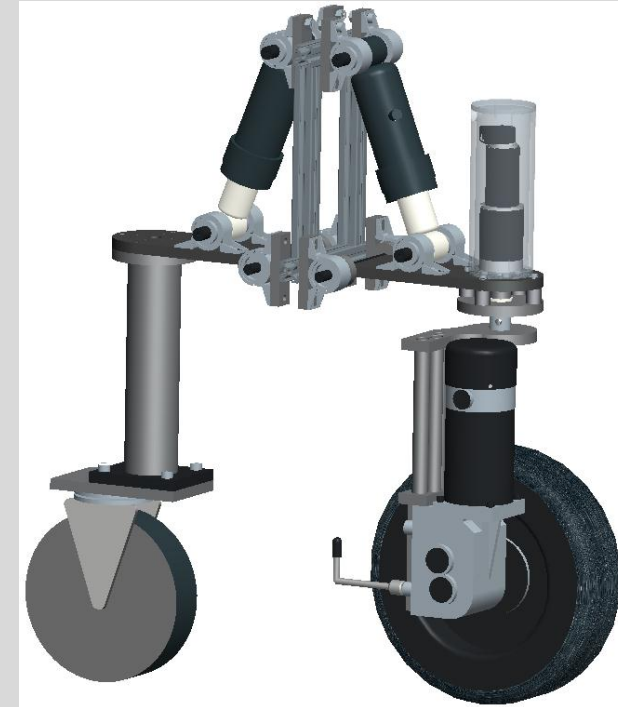

CAD of propulsion system used in finalized design

Specifications

Control & Function:

- Intuitive user input
 - Force-based drive control
- Proposed control algorithms
 - Fall prevention
 - Sit-down / stand-up assistance
 - Object detection / avoidance
 - Localization & navigation

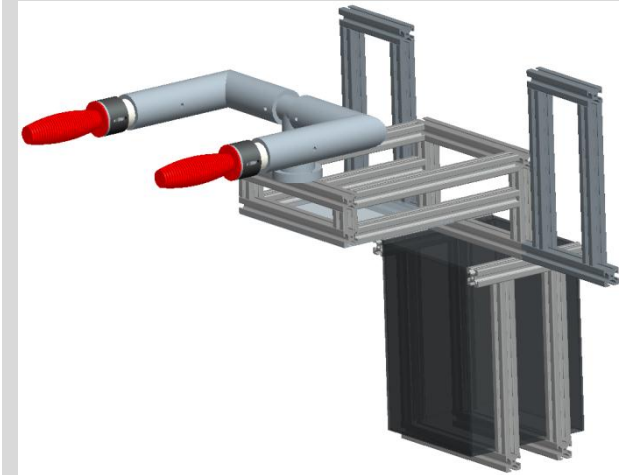

CAD of control systems used in finalized design

Design Criteria

Frame



Propulsion



Control & Function

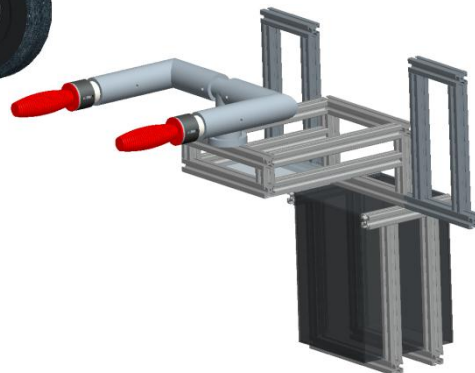

Maximize:

- Versatility
- Robustness
- User-friendliness
- Indoor operation
- Outdoor operation

Minimize:

- Cost
- Weight

- 1) Project Introduction**
- 2) Design Specifications**
- 3) Concept Generation**
- 4) Interim Designs**
- 5) Final Design**
- 6) Manufacturing & Assembly**
- 7) Testing & Results**
- 8) Discussion & Conclusions**

Initial Designs

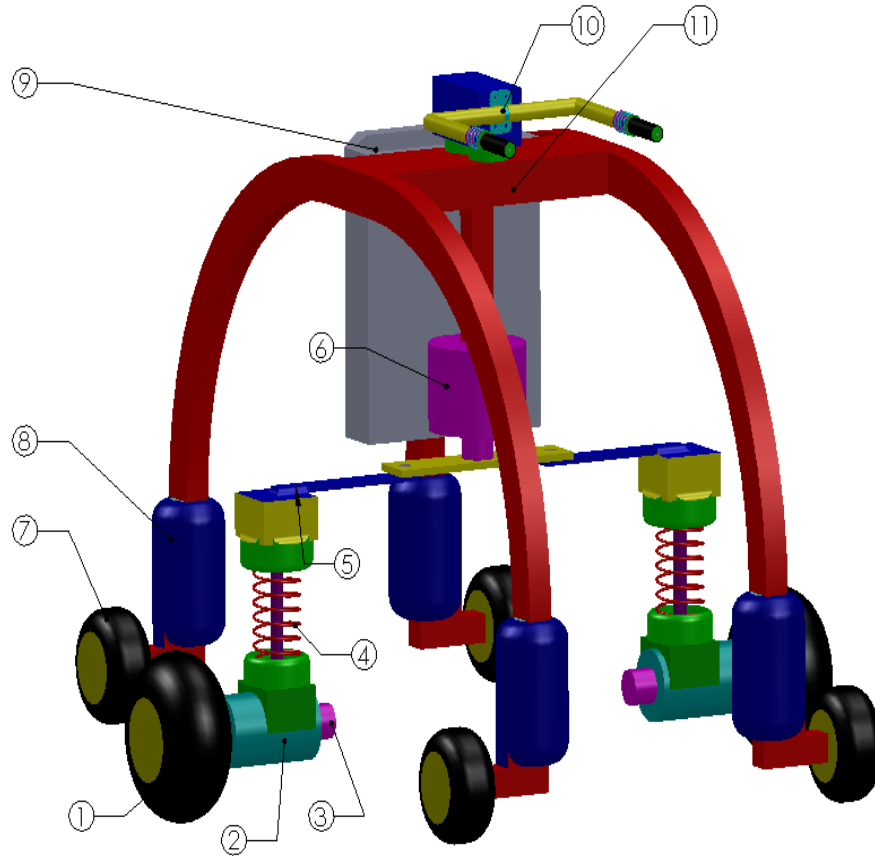

Initial Design 1

Initial Designs

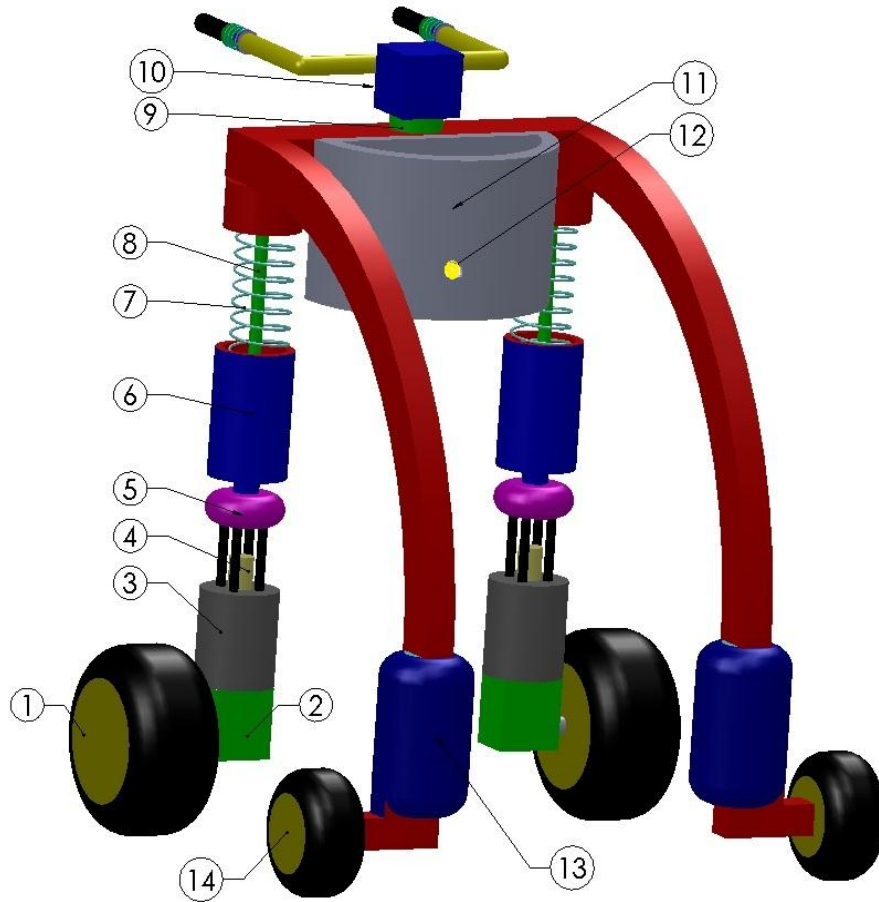
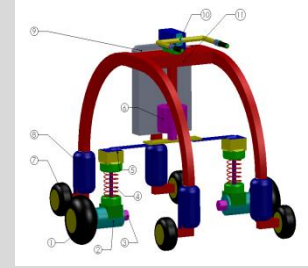

Initial Design 2

Initial Designs

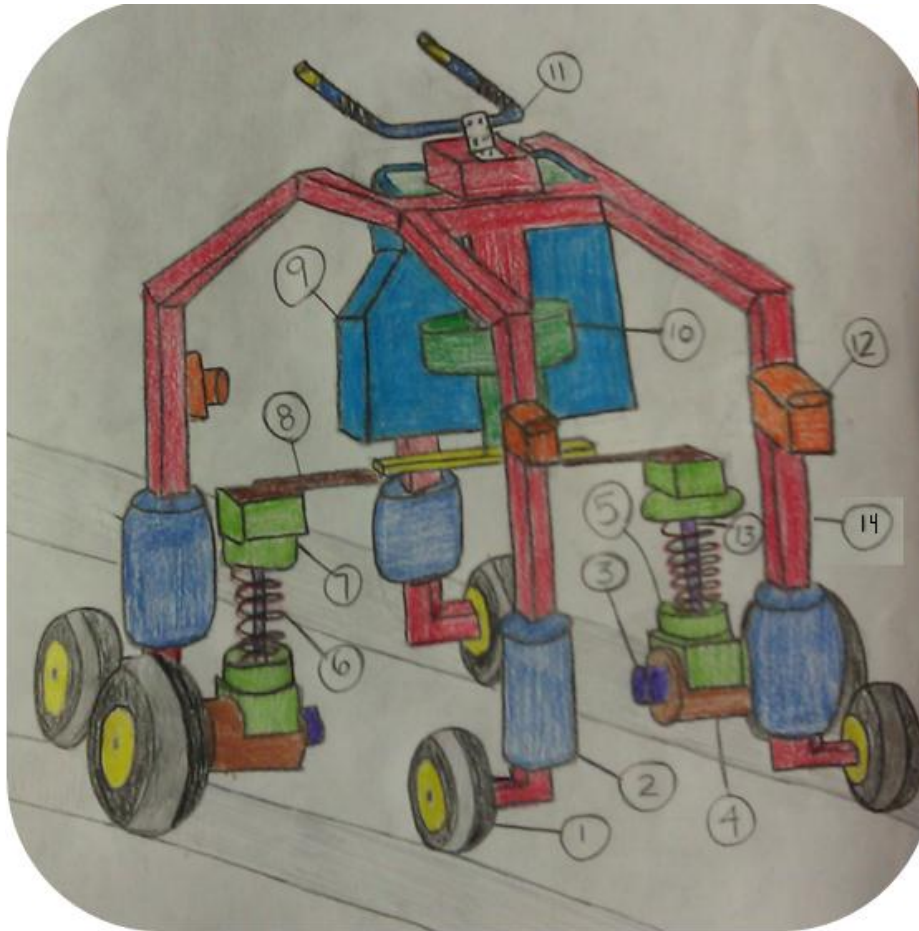

Initial Design 3

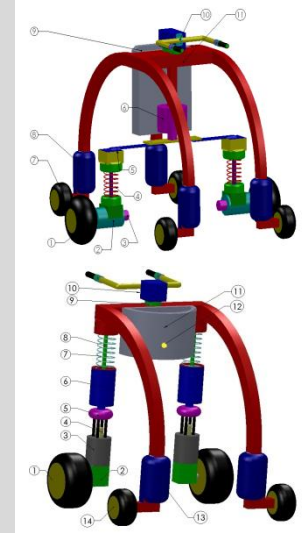

Initial Designs

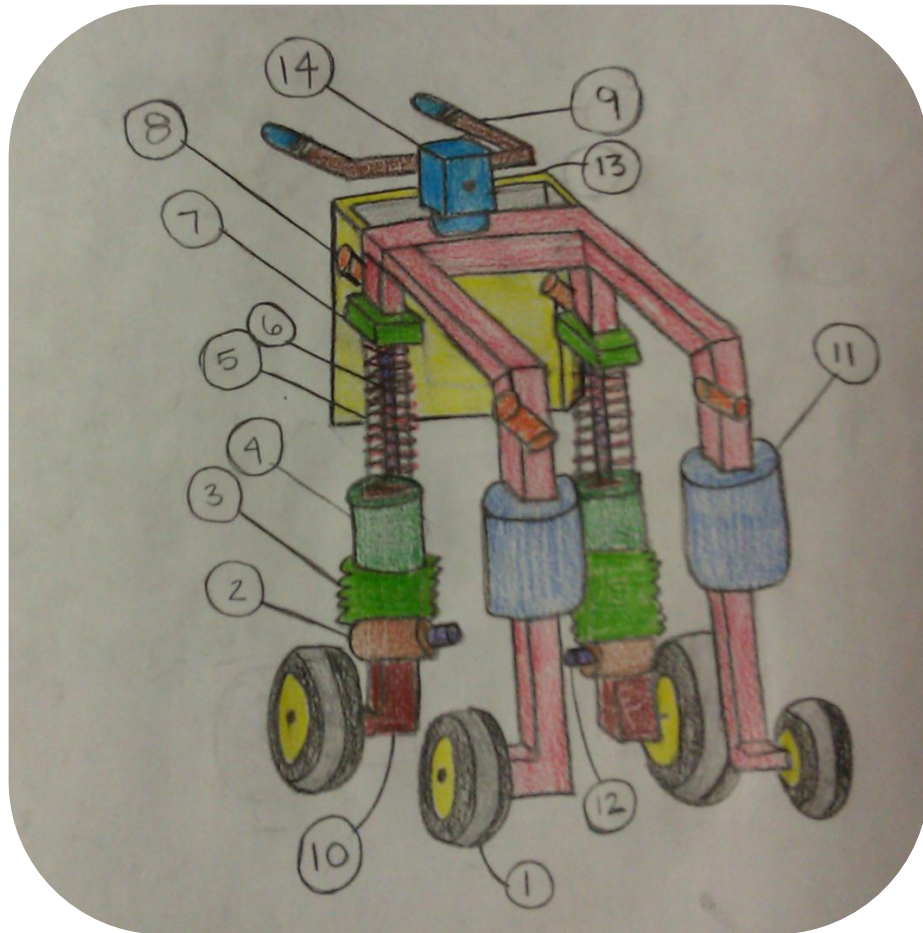

Initial Design 4

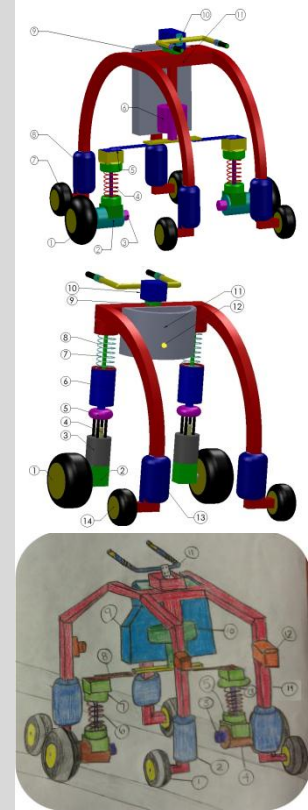

Initial Designs

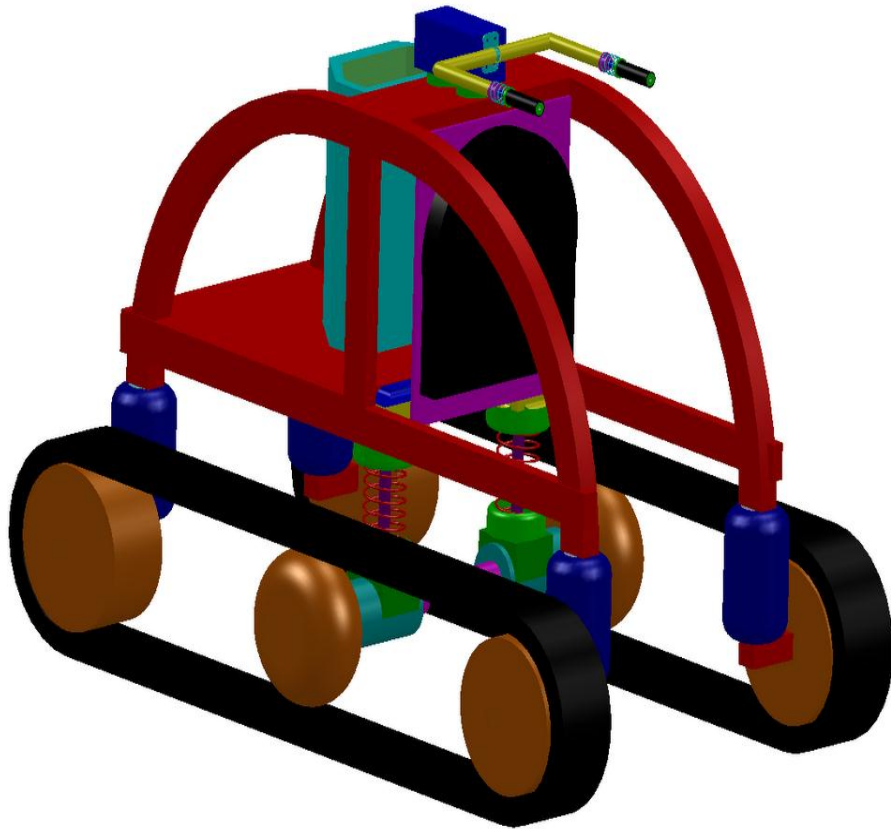

Initial Design 5

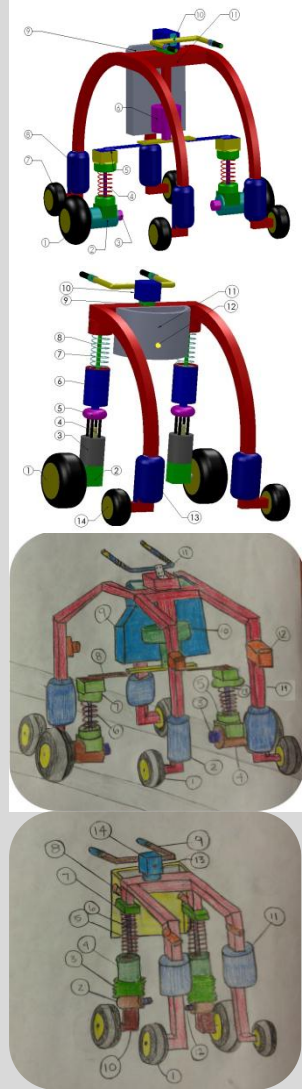

Decision Matrix

| | | Initial 1 | | Initial 2 | | Initial 3 | | Initial 4 | | Initial 5 | |
|-------------------|--------|-----------|----------------|-----------|----------------|-----------|----------------|-----------|----------------|-----------|----------------|
| | Weight | Score | Weighted Score | Score | Weighted Score | Score | Weighted Score | Score | Weighted Score | Score | Weighted Score |
| Versatility | 0.15 | 3 | 0.454 | 5 | 0.757 | 3 | 0.454 | 3 | 0.454 | 3 | 0.454 |
| Robustness | 0.17 | 4 | 0.699 | 3 | 0.524 | 5 | 0.874 | 3 | 0.524 | 4 | 0.699 |
| User-friendliness | 0.22 | 3 | 0.670 | 4 | 0.894 | 2 | 0.447 | 5 | 1.117 | 3 | 0.670 |
| Cost | 0.04 | 2 | 0.086 | 2 | 0.086 | 1 | 0.043 | 1 | 0.043 | 1 | 0.043 |
| Indoor | 0.14 | 3 | 0.429 | 3 | 0.429 | 2 | 0.286 | 3 | 0.429 | 1 | 0.143 |
| Outdoor | 0.23 | 4 | 0.926 | 3 | 0.695 | 3 | 0.695 | 2 | 0.463 | 5 | 1.158 |
| Weight | 0.03 | 2 | 0.066 | 3 | 0.099 | 1 | 0.033 | 4 | 0.132 | 1 | 0.033 |
| | Sum | | 3.331 | | 3.483 | | 2.832 | | 3.163 | | 3.200 |

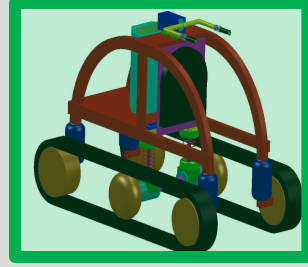
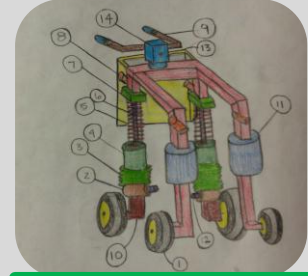
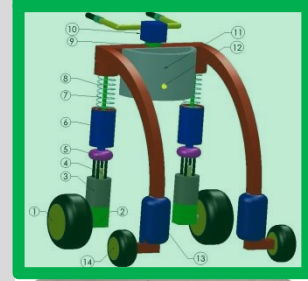
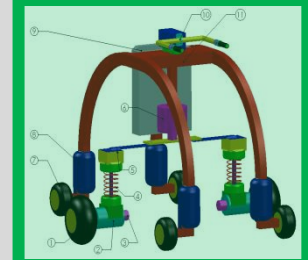

- 1) Project Introduction**
- 2) Design Specifications**
- 3) Concept Generation**
- 4) Interim Designs**
- 5) Final Design**
- 6) Manufacturing & Assembly**
- 7) Testing & Results**
- 8) Discussion & Conclusions**

Interim Designs

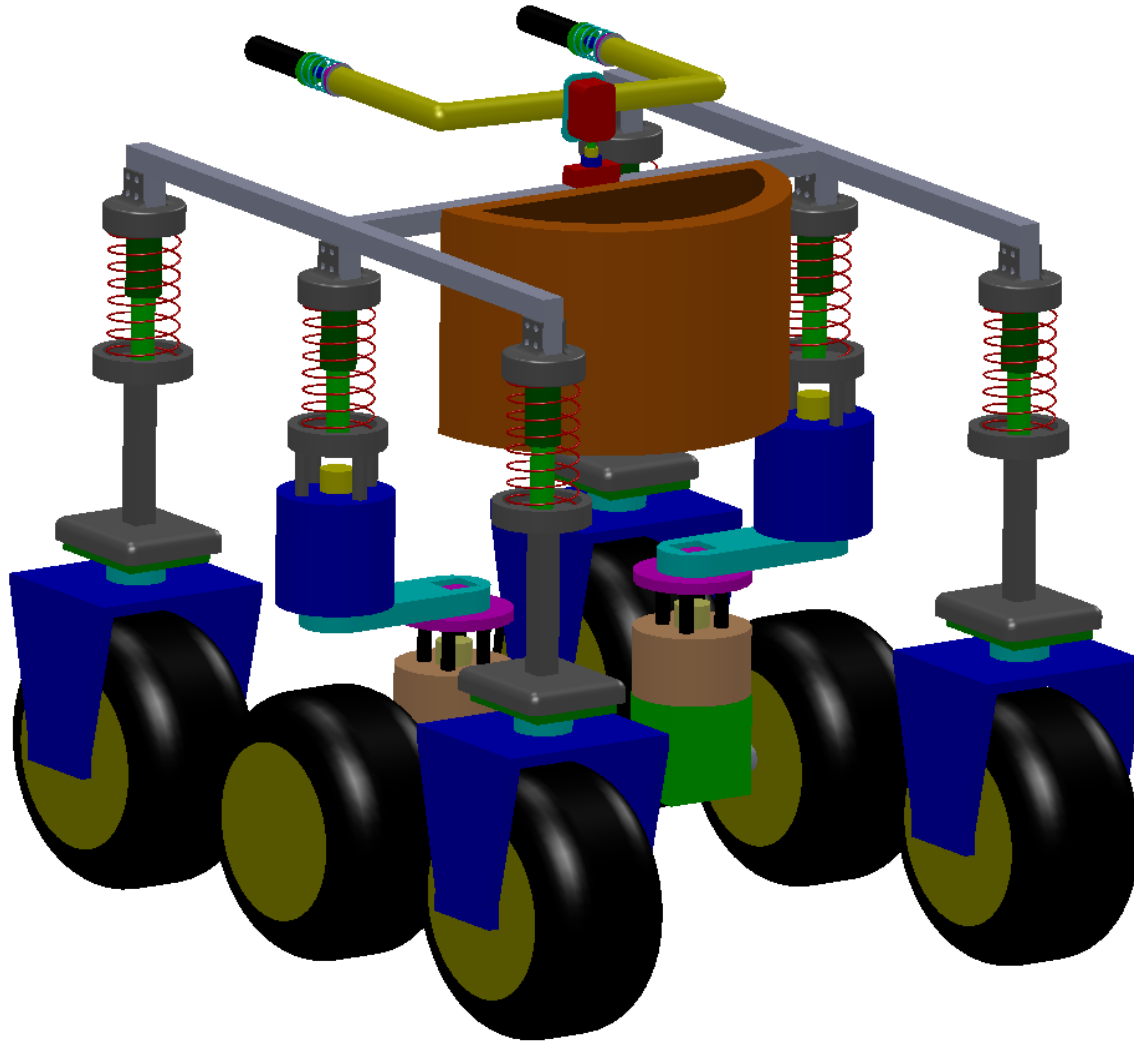

Interim Design 1

Problems:

1. Zero offset passive casters
2. No horizontal shock absorption
3. Too constricting to user

Interim Designs

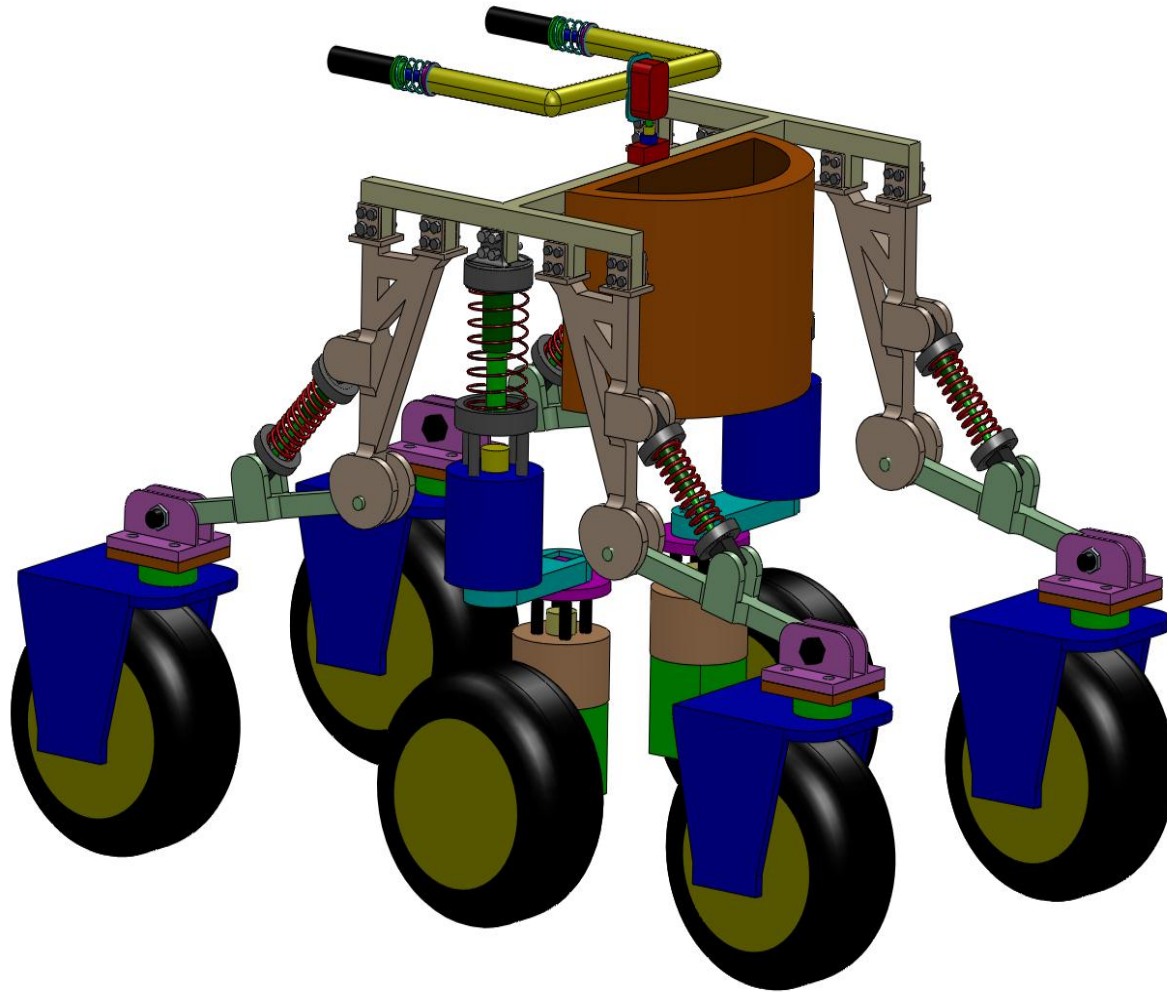

Interim Design 2

Fixes:

1. Swivel offset casters
2. Angled caster suspension
3. Smaller user restriction

Interim Designs

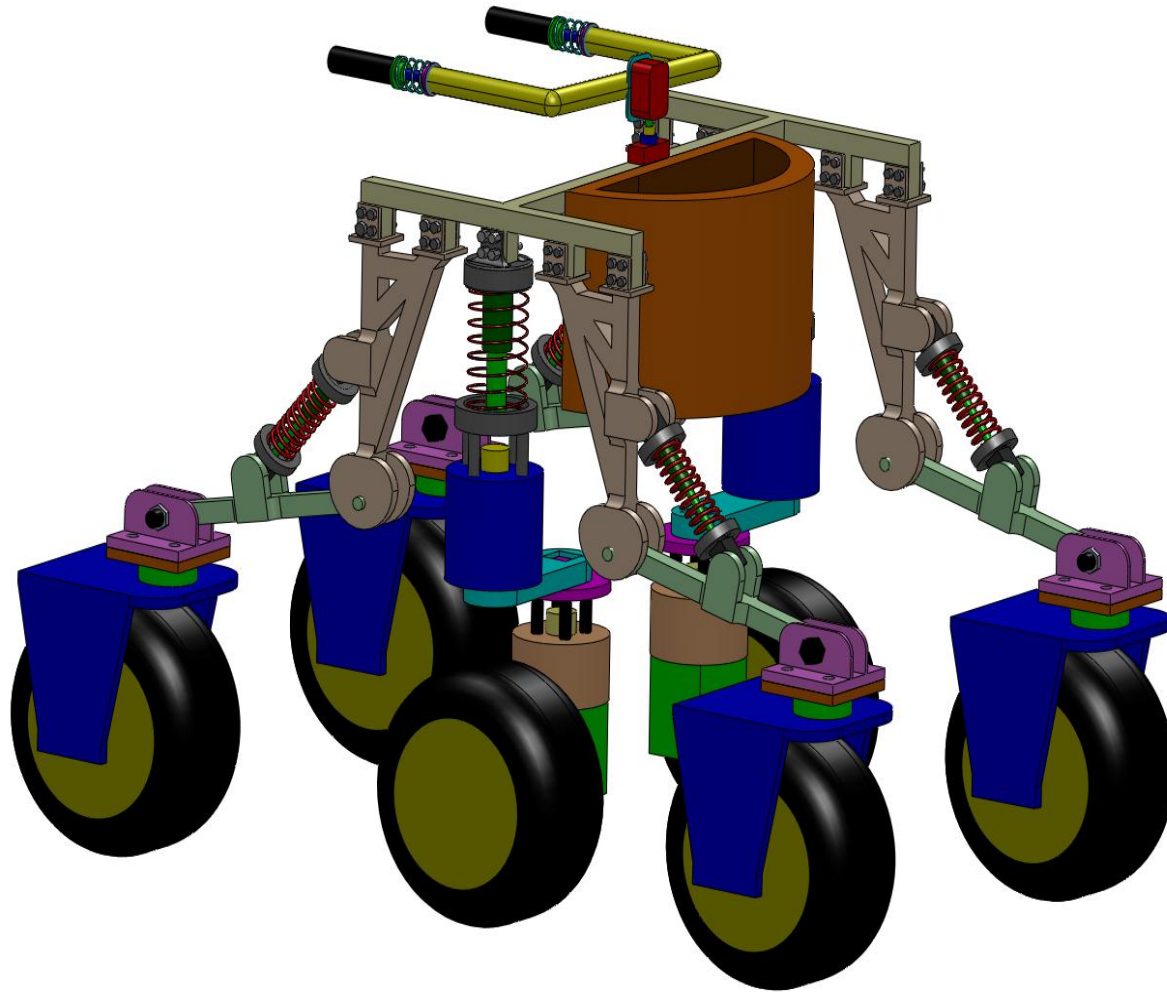

Interim Design 2

Problems:

1. No horizontal support for driving wheels
2. Low maneuverability
3. No room to house power and control systems

Interim Designs

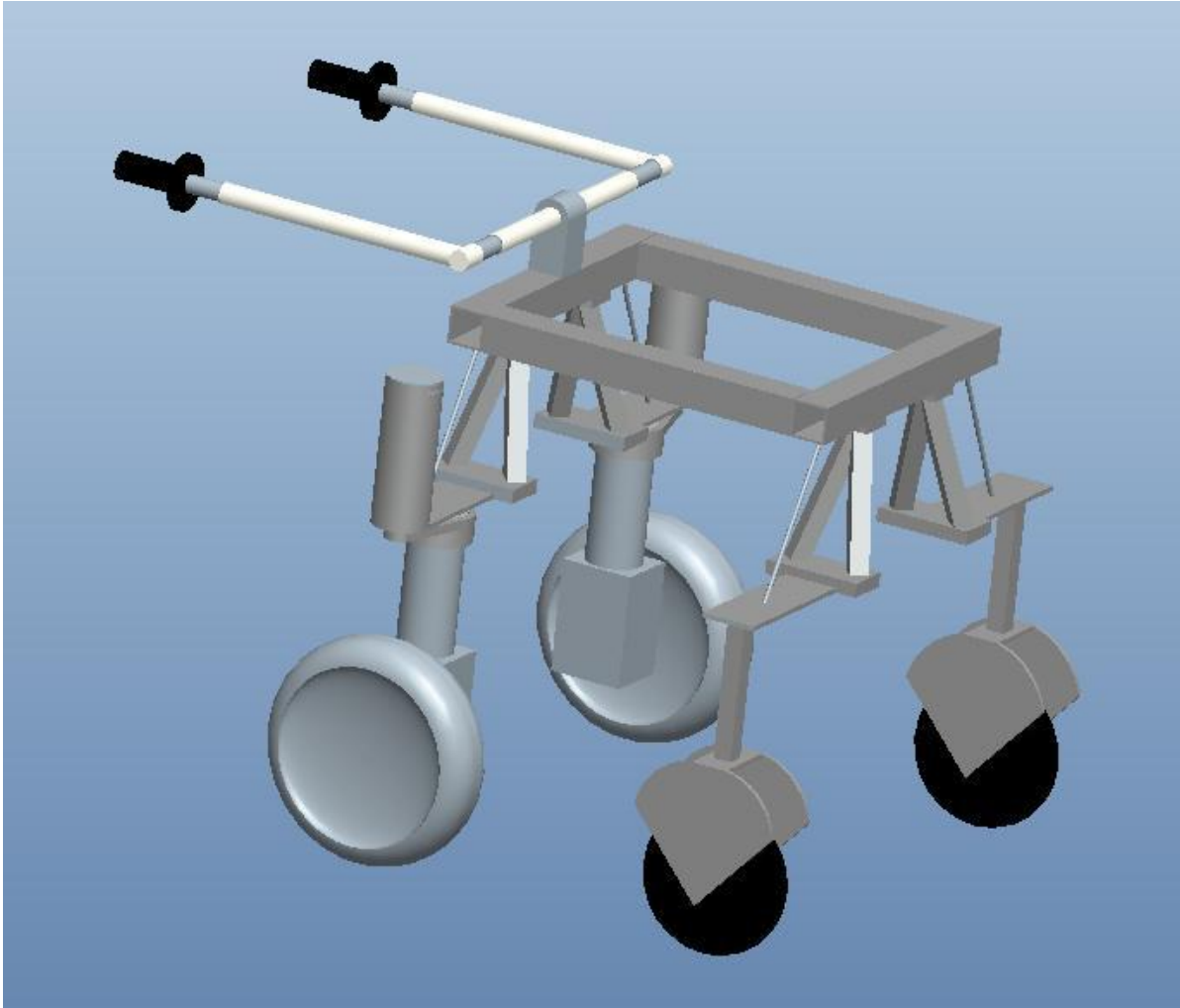

Interim Design 3

Fixes:

1. Angled suspension for all wheels
2. Four wheel design
3. Larger frame area to house electrical components

Interim Designs

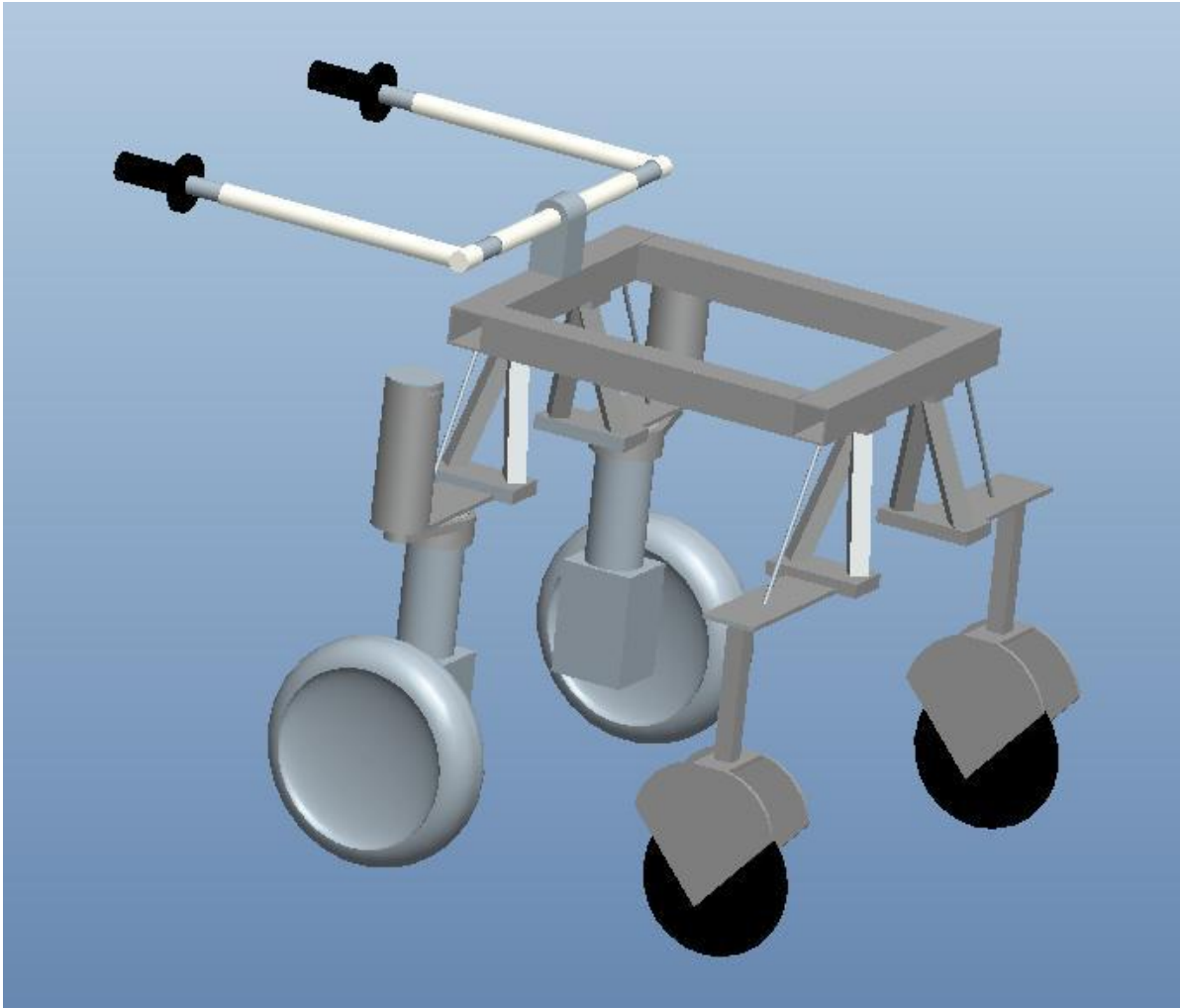

Interim Design 3

Problems:

1. 90° offset of suspension
2. Poor / unavailable material choices
3. Flimsy handles

- 1) Project Introduction**
- 2) Design Specifications**
- 3) Concept Generation**
- 4) Interim Designs**
- 5) Final Design**
- 6) Manufacturing & Assembly**
- 7) Testing & Results**
- 8) Discussion & Conclusions**

Final Design

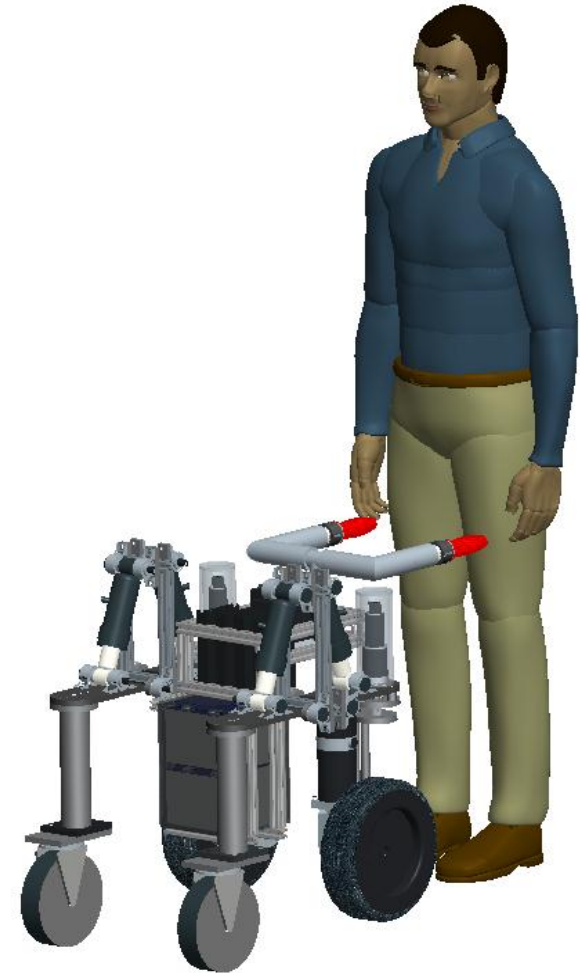
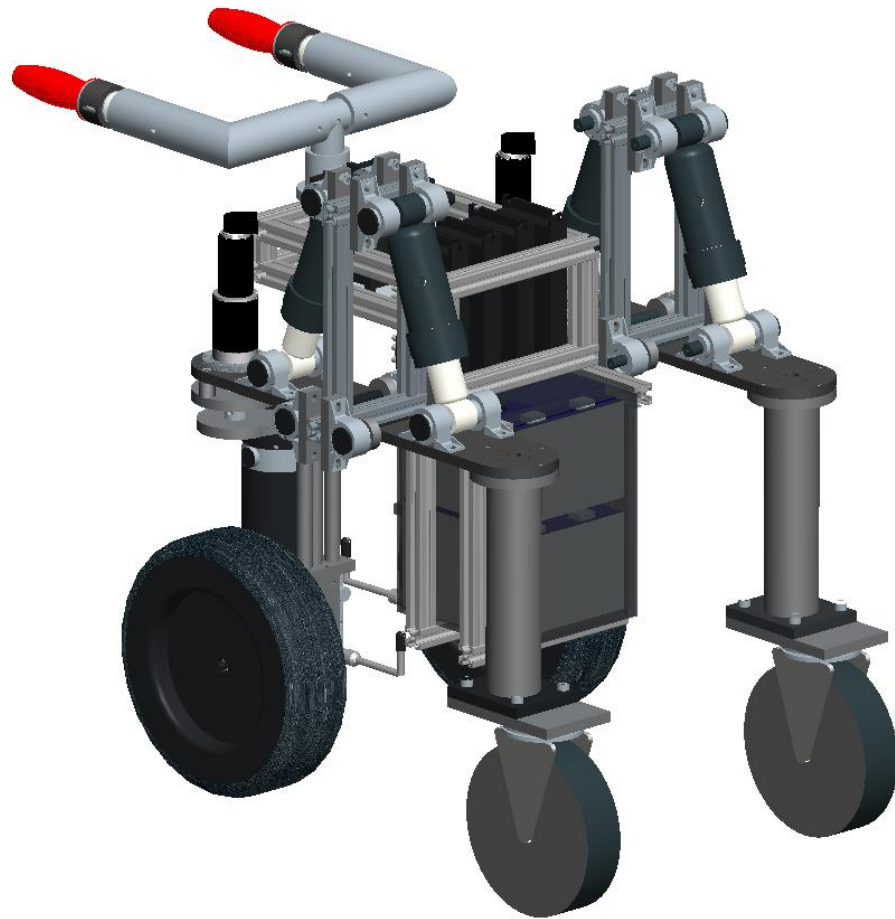

Final Design

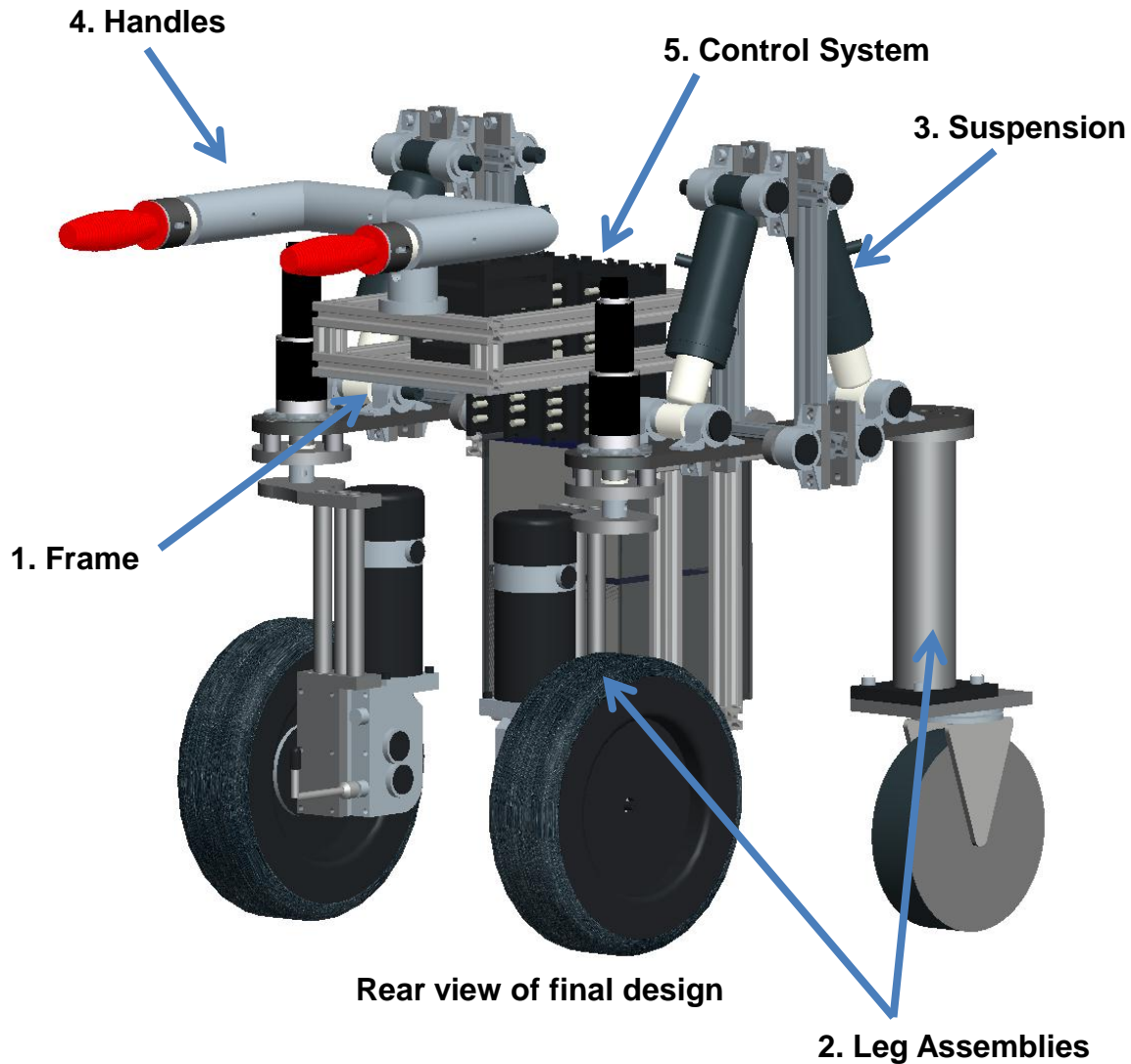

Major Components:

1. Frame
2. Leg Assemblies
3. Suspension
4. Handles
5. Control System

Frame

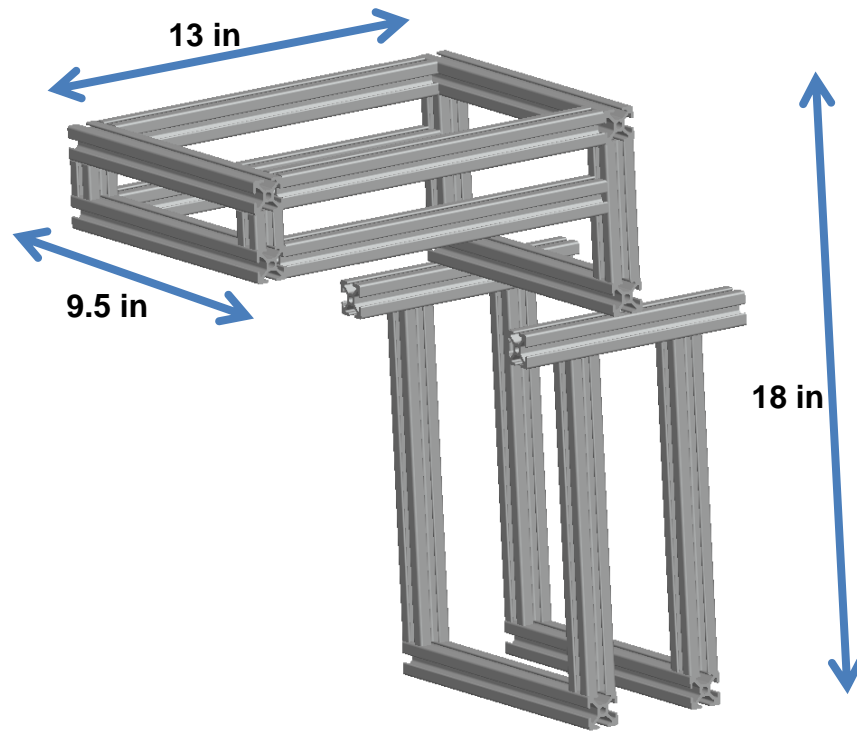

Basic frame structure

Dimensions:

- Width: 9.5 in
- Length: 13 in
- Height: 18 in

Frame

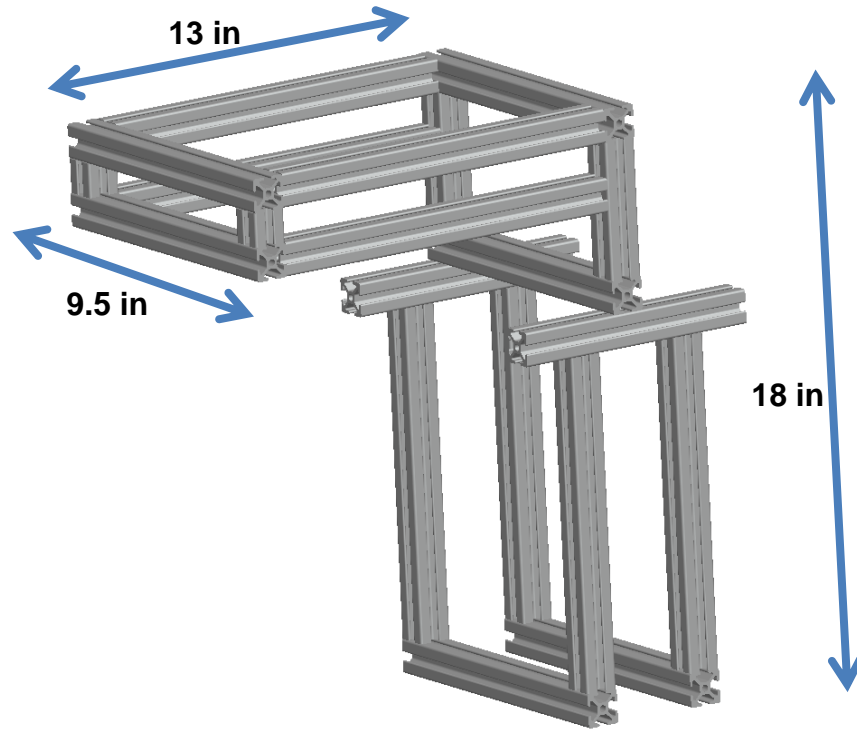

Basic frame structure

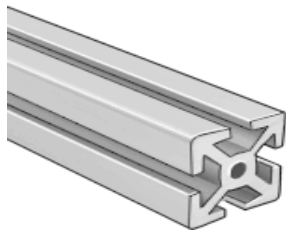

1x1 inch t-slotted 80/20

<http://www.mcmaster.com/#catalog/118/1922/=gx58qp>

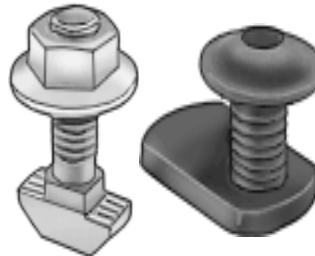

Primary attachment pieces

<http://www.mcmaster.com/#catalog/118/1924/=gx5d84>

Dimensions:

- Width: 9.5 in
- Length: 13 in
- Height: 18 in

Features:

- 1x1 inch t-slotted aluminum 80/20
- Variable mounting locations
- Design evolution

Leg Assemblies

Caster Wheels

Dimensions:

- Diameter: 8 in
- Width: 1.5 in
- Height: 20.25 in

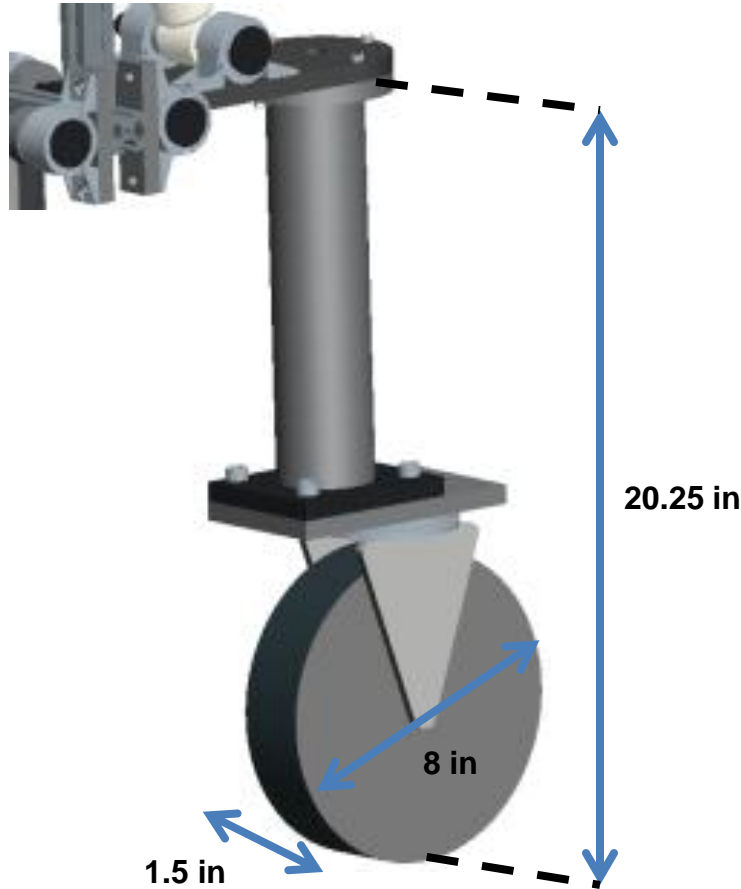

Final caster wheel design

Leg Assemblies

Caster Wheels

Dimensions:

- Diameter: 8 in
- Width: 1.5 in
- Height: 20.25 in

Features:

- Solid rubber
- Offset swivel
- Modular mounting plate

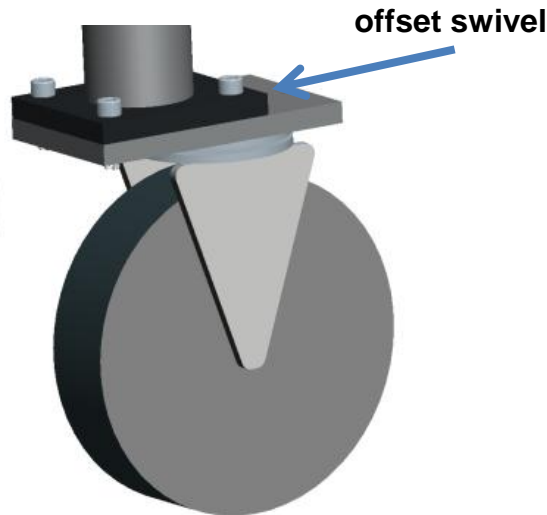

Offset swivel caster wheel

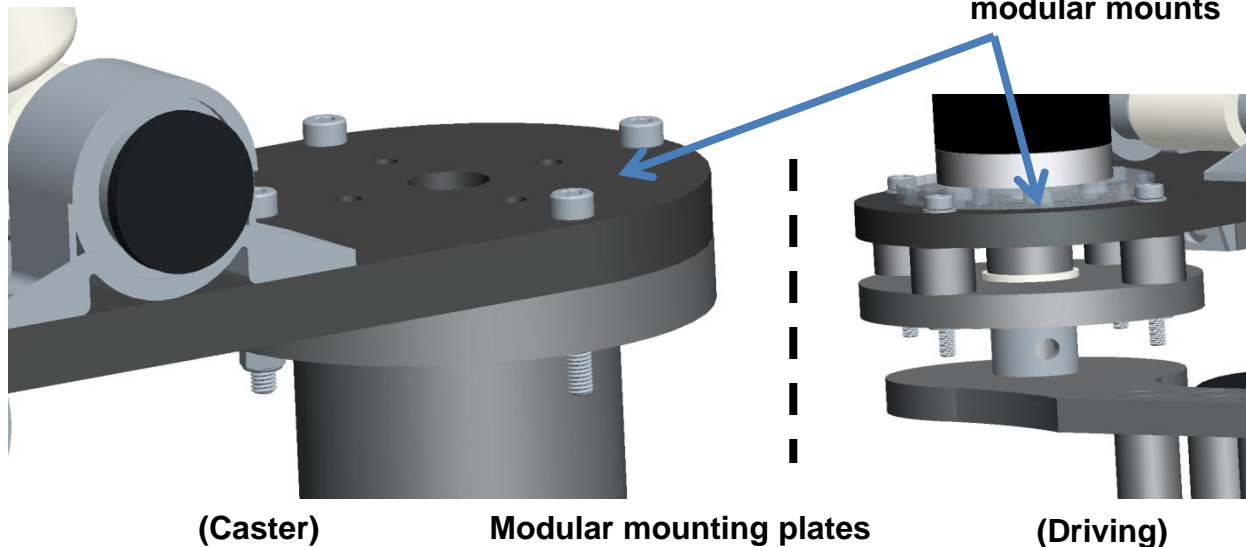

(Caster)

Modular mounting plates

(Driving)

Leg Assemblies

Driving Wheels

Dimensions:

- Diameter: 12 in
- Width: 4 in
- Height: 20.25 in

Features:

- Air filled / Metal rimmed
- Preexisting mounting holes

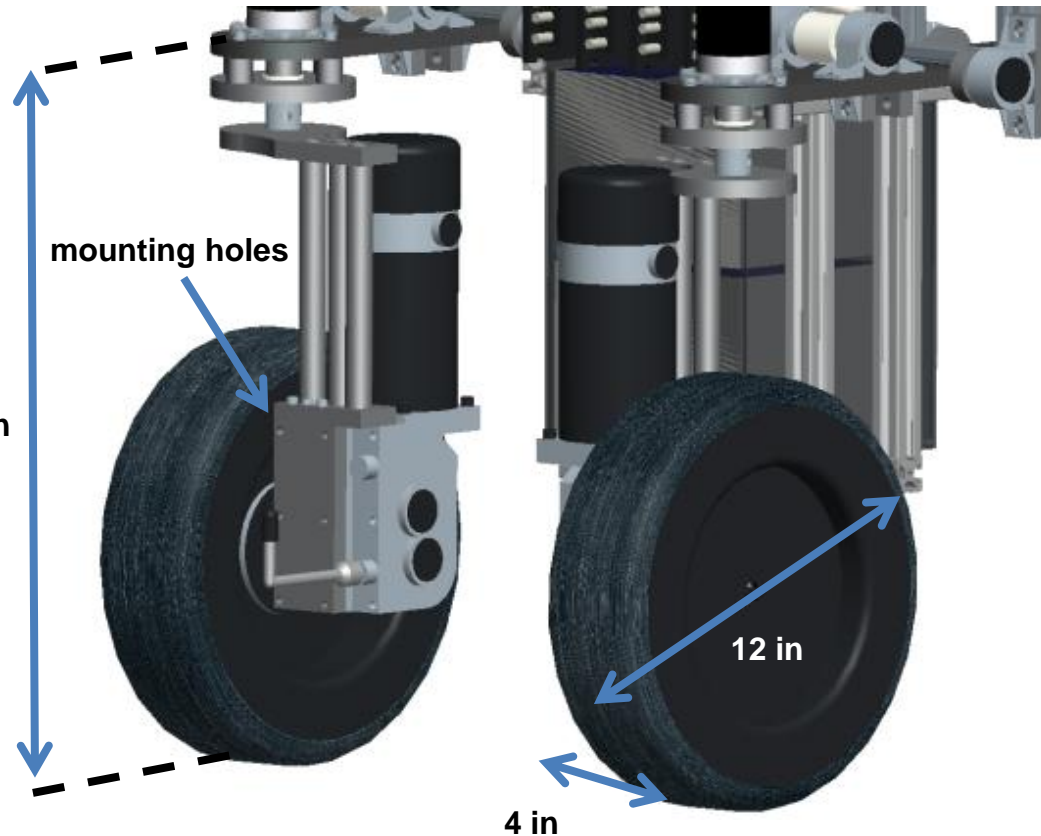

Final driving wheel design

Leg Assemblies

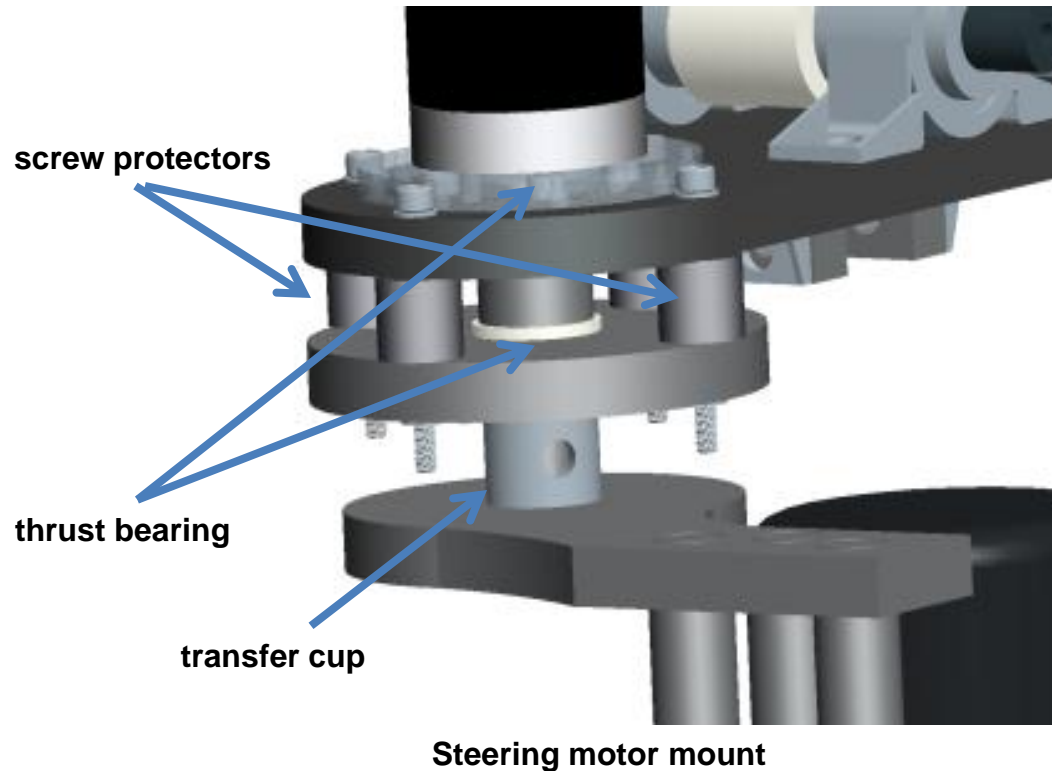

Driving Wheels

Dimensions:

- Diameter: 12 in
- Width: 4 in
- Height: 20.25 in

Features:

- Air filled / Metal rimmed
- Preexisting mounting holes
- Transfer cup
- Screw protectors
- Thrust bearings

Leg Assemblies

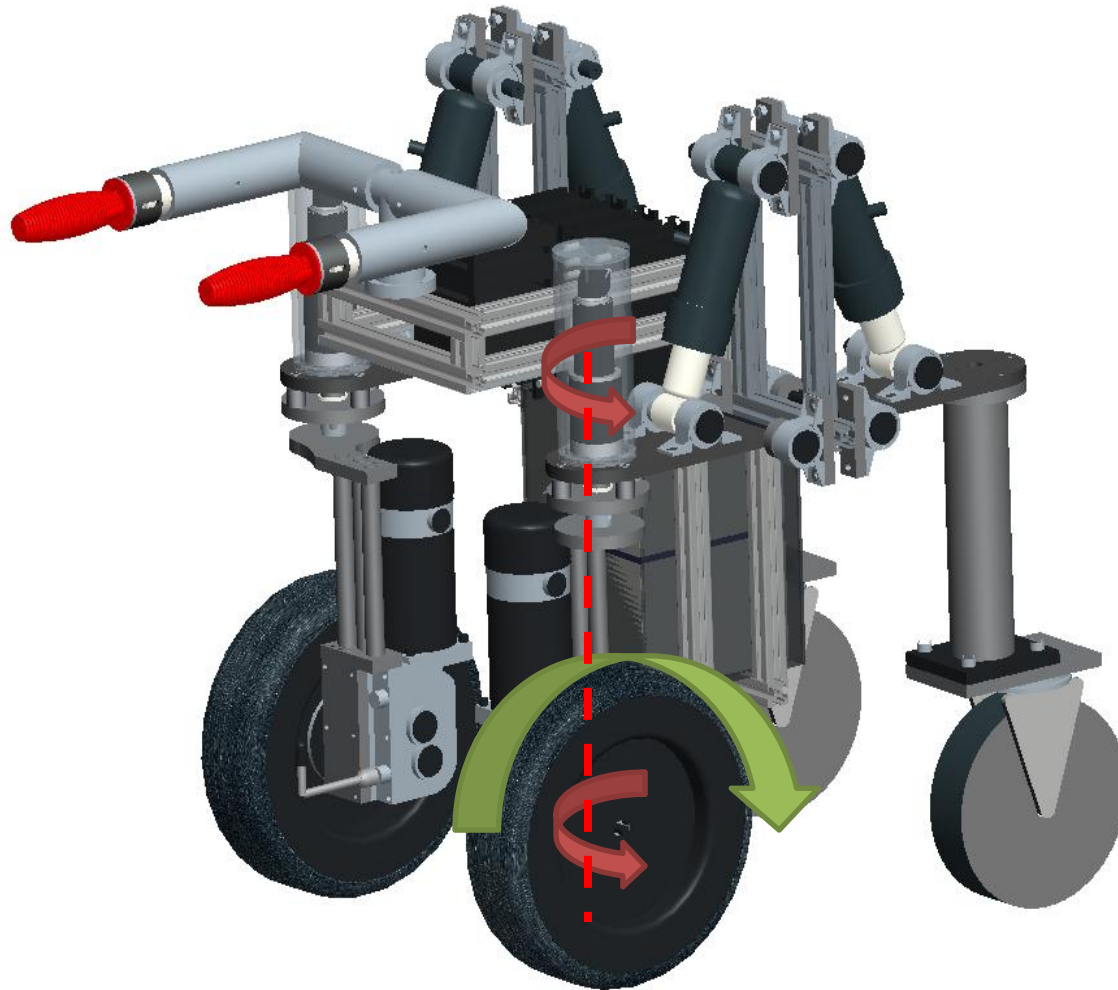

Motor spin diagram

Driving Wheels

Dimensions:

- Diameter: 12 in
- Width: 4 in
- Height: 20.25 in

Features:

- Air filled / Metal rimmed
- Preexisting mounting holes
- Transfer cup
- Screw protectors
- Thrust bearings

Suspension

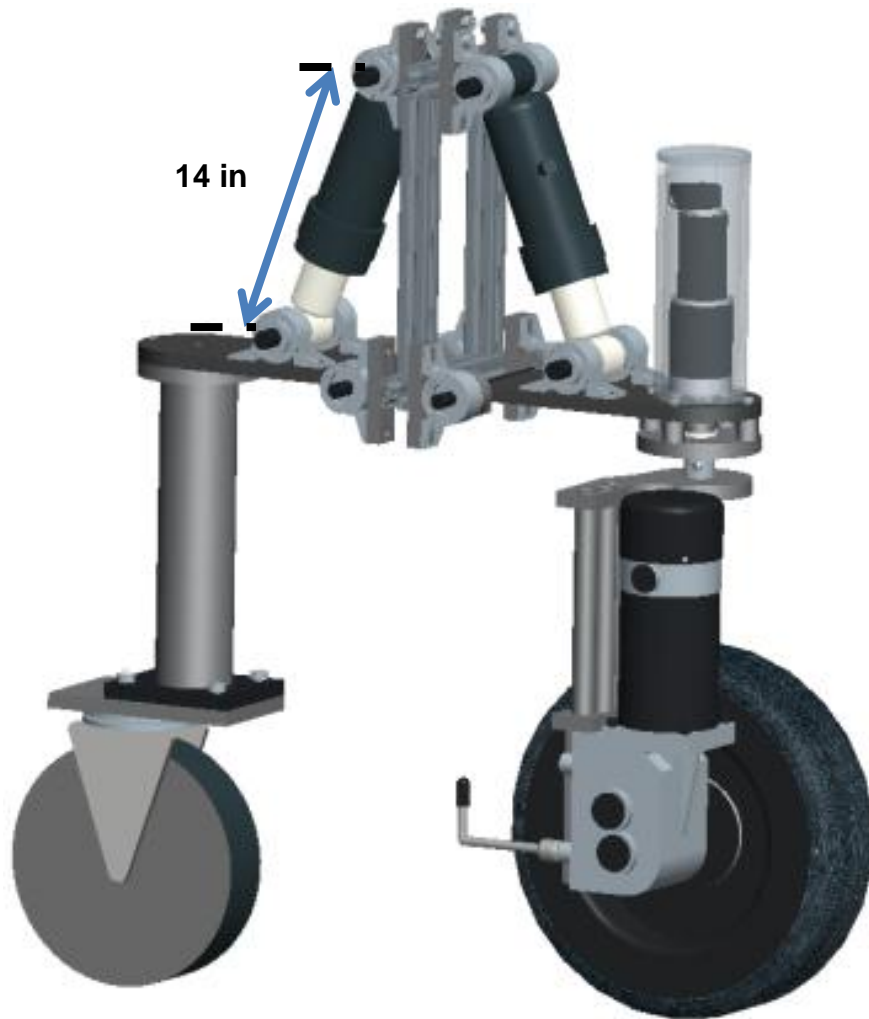

Final suspension design

Dimensions:

- Natural: 14 in
- Compressed: 9.375 in

Suspension

Dimensions:

- Natural: 14 in
- Compressed: 9.375 in

Features:

- Monroe Max-Air adjustable air shocks
- Same for all wheels
 - Modular

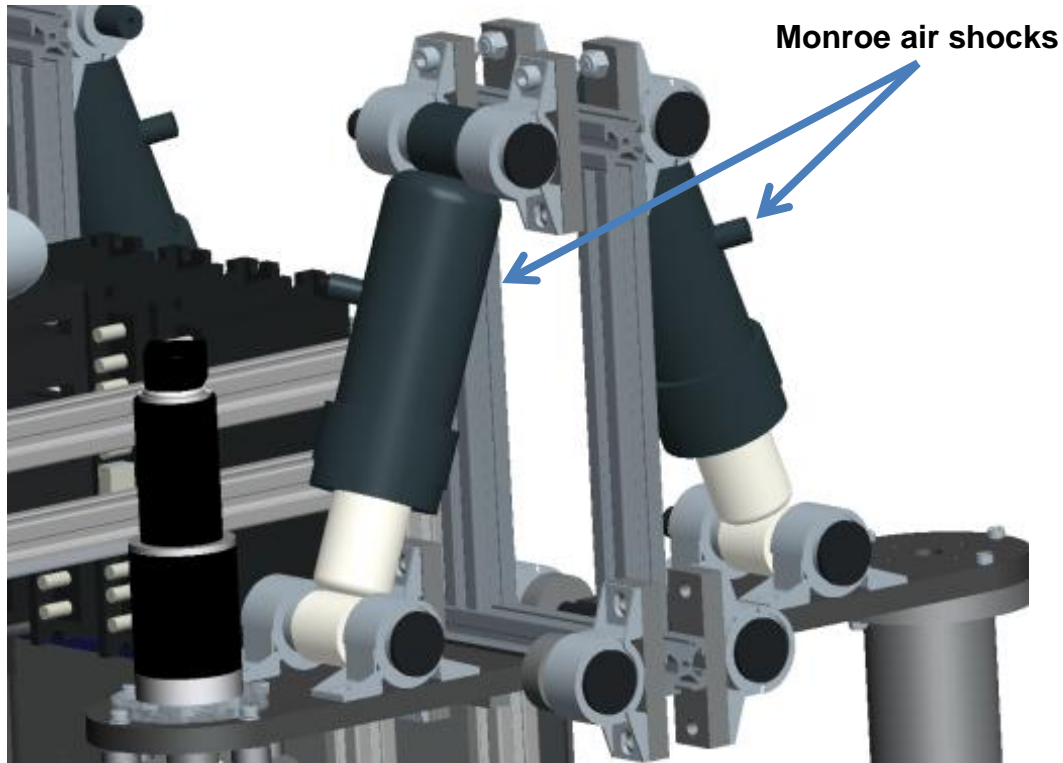

Suspension mount

Suspension

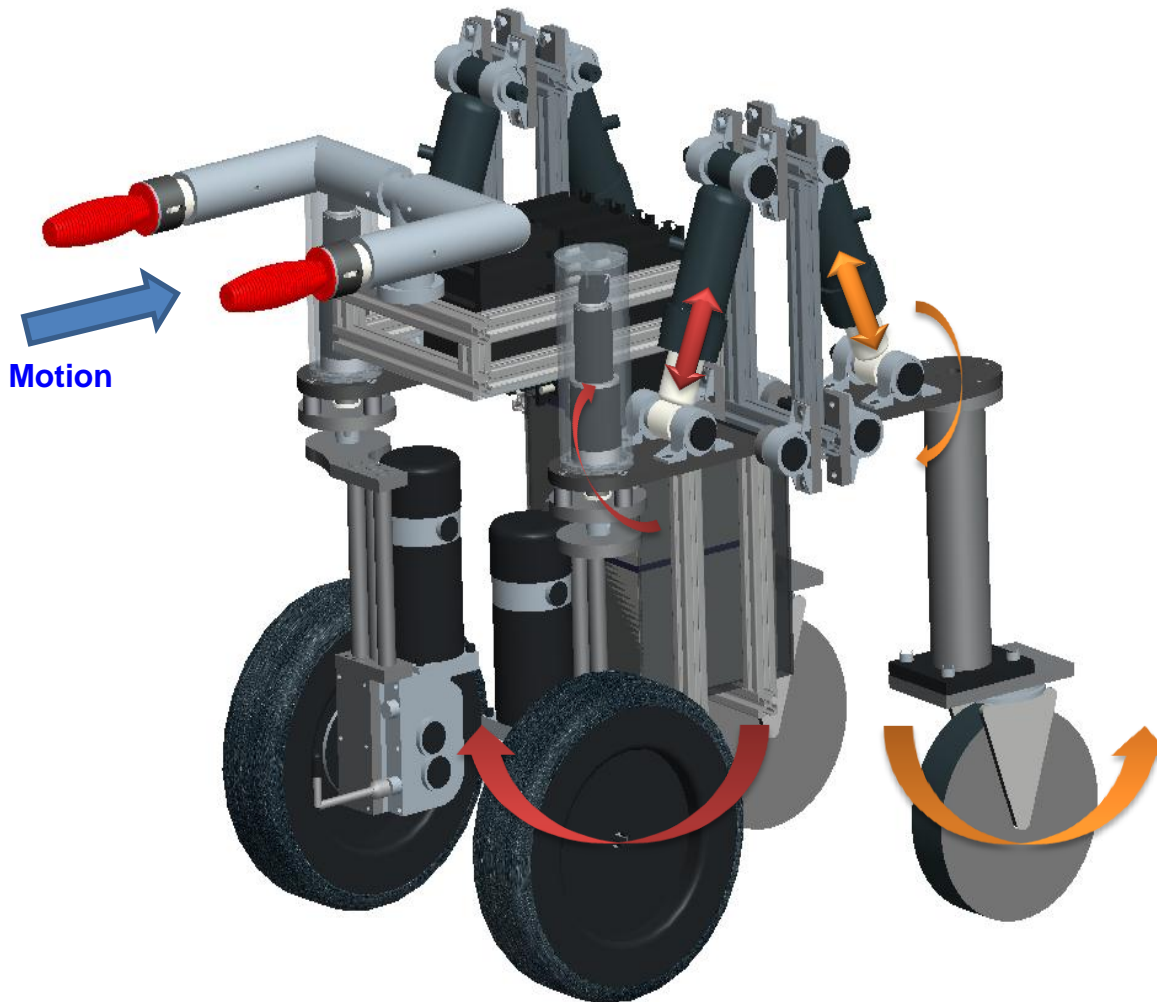

Suspension movement diagram

Dimensions:

- Natural: 14 in
- Compressed: 9.375 in

Features:

- Monroe Max-Air adjustable air shocks
- Same for all wheels
 - Modular
- In-line with direction of travel

Handles

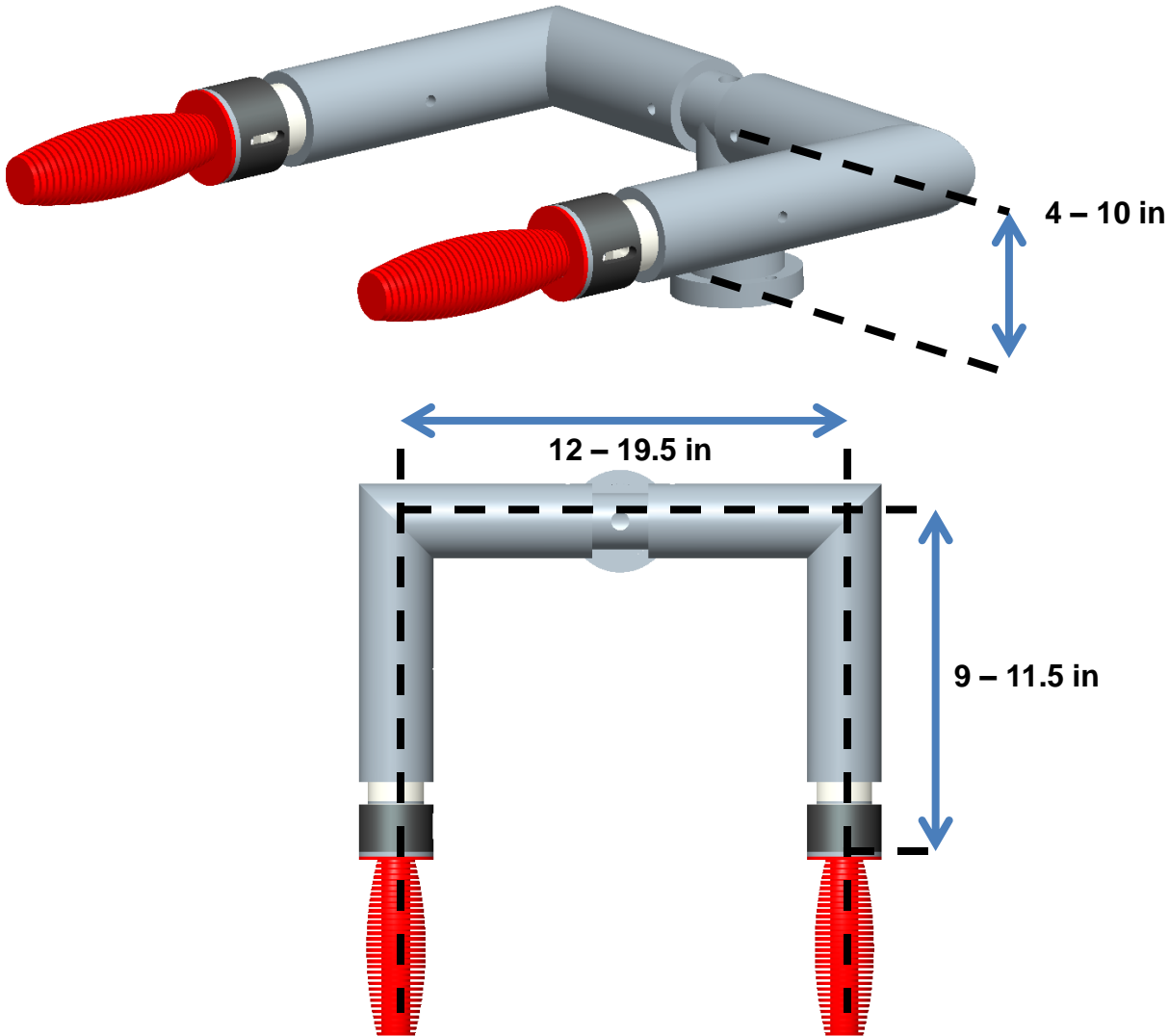

Final handle design

Dimensions:

- Width: 12 – 19.5 in
- Depth: 9 – 11.5 in
- Height: 4 – 10 in

Handles

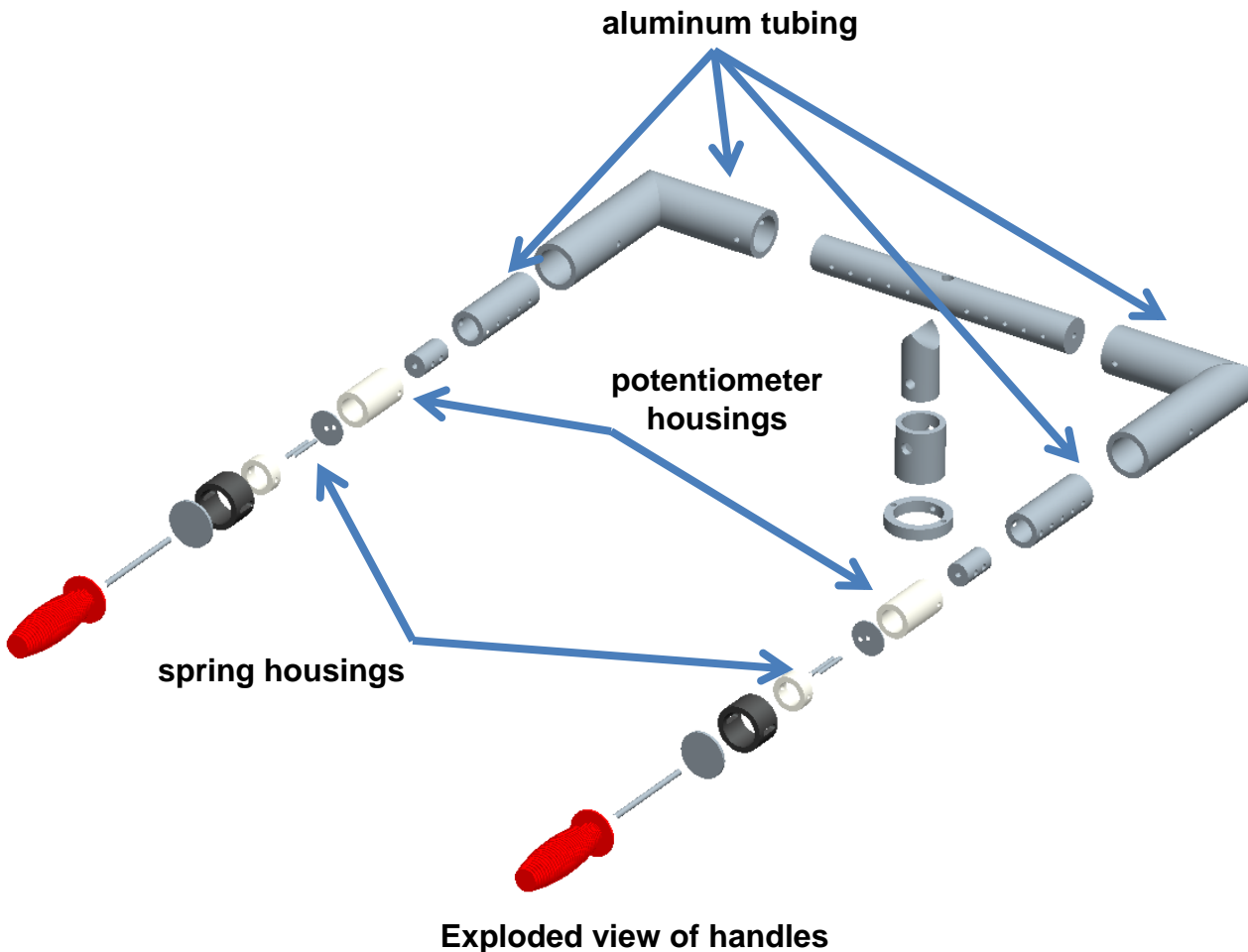

Dimensions:

- Width: 12 – 19.5 in
- Depth: 9 – 11.5 in
- Height: 4 – 10 in

Features:

- Concentric aluminum tubing
- Linear potentiometers
- Interchangeable spring housing

Control System

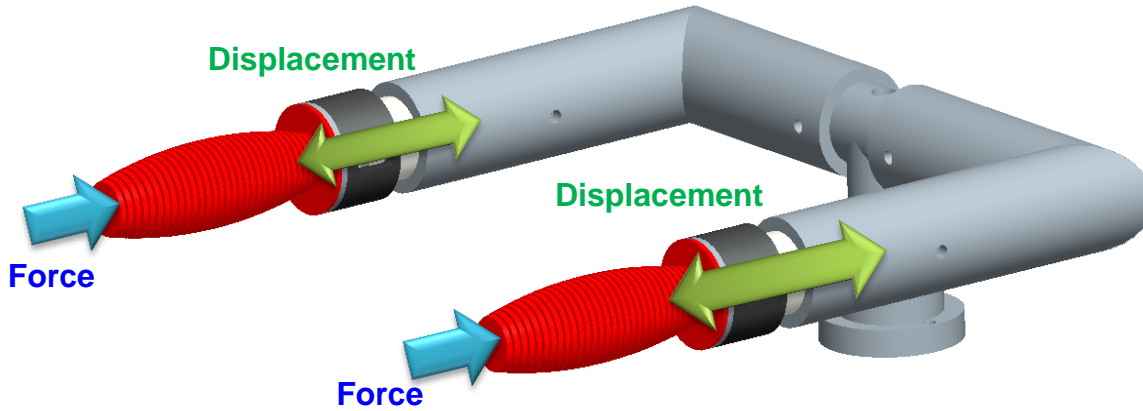

Force – displacement diagrams

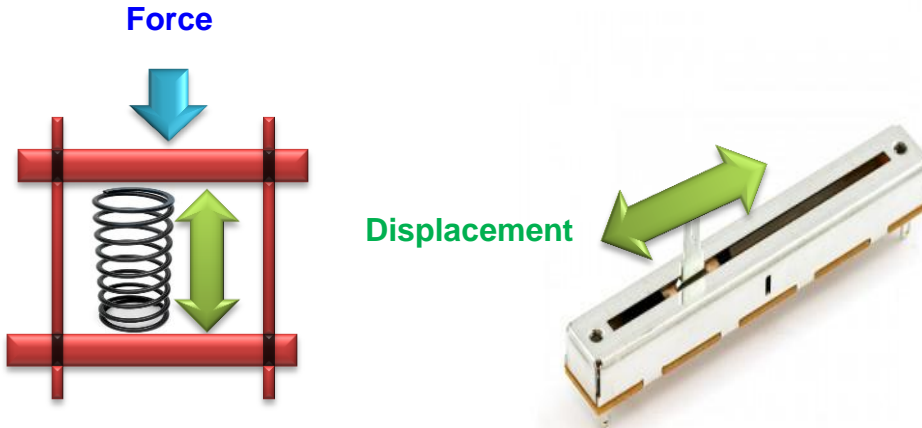

User Input

- 2 – exchangeable linear compression springs
- 2 – 10k Ω linear potentiometers

Control System

User Input

- 2 – exchangeable linear compression springs
- 2 – 10kΩ linear potentiometers

Control

- 1 – PC104 computer stack
- 4 – brushed motor drivers

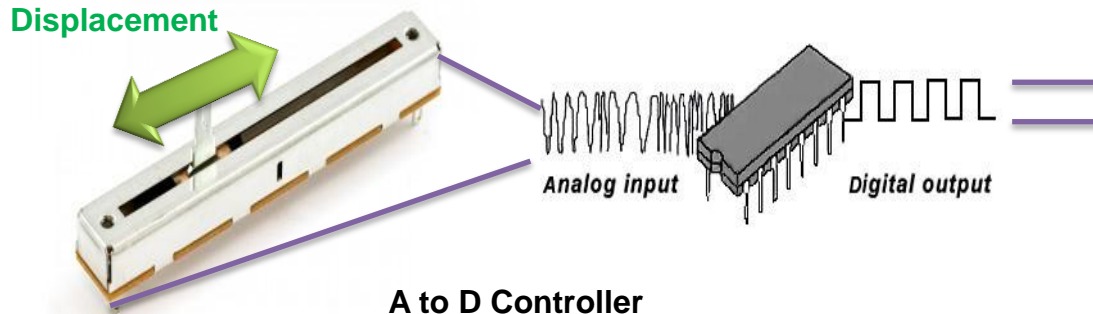

A to D Controller

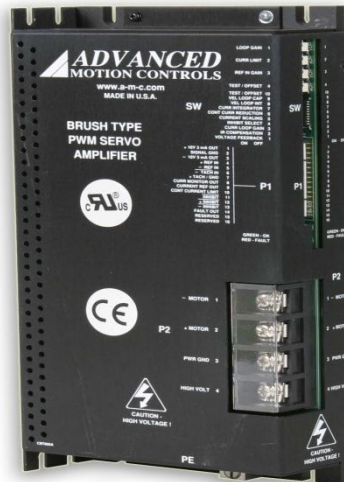

Motor driver

<http://www.a-m-c.com/images/productpics/120a10.jpg>

Control System

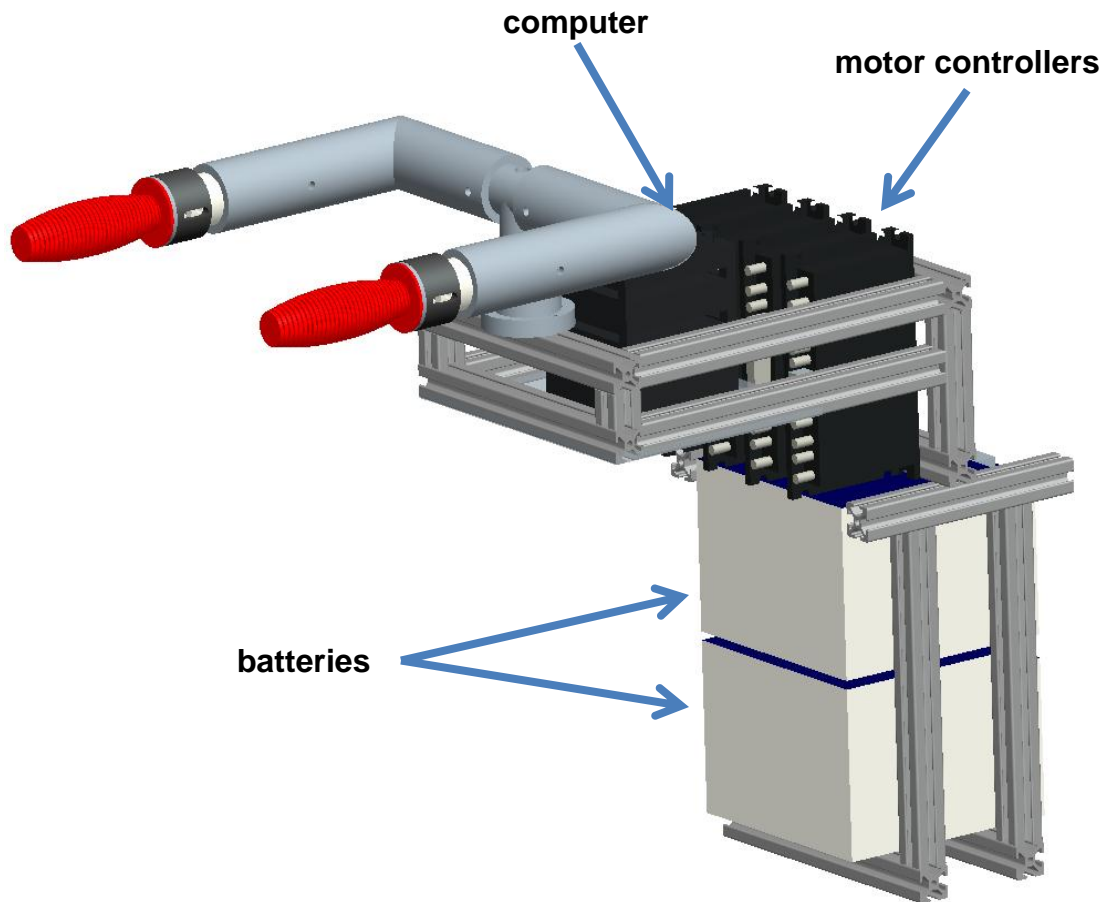

Full control system and frame set-up

User Input

- 2 – exchangeable linear compression springs
- 2 – 10k Ω linear potentiometers

Control

- 1 – PC104 computer stack
- 4 – brushed motor drivers

Power

- 2 – 12V lead acid batteries

Final Design

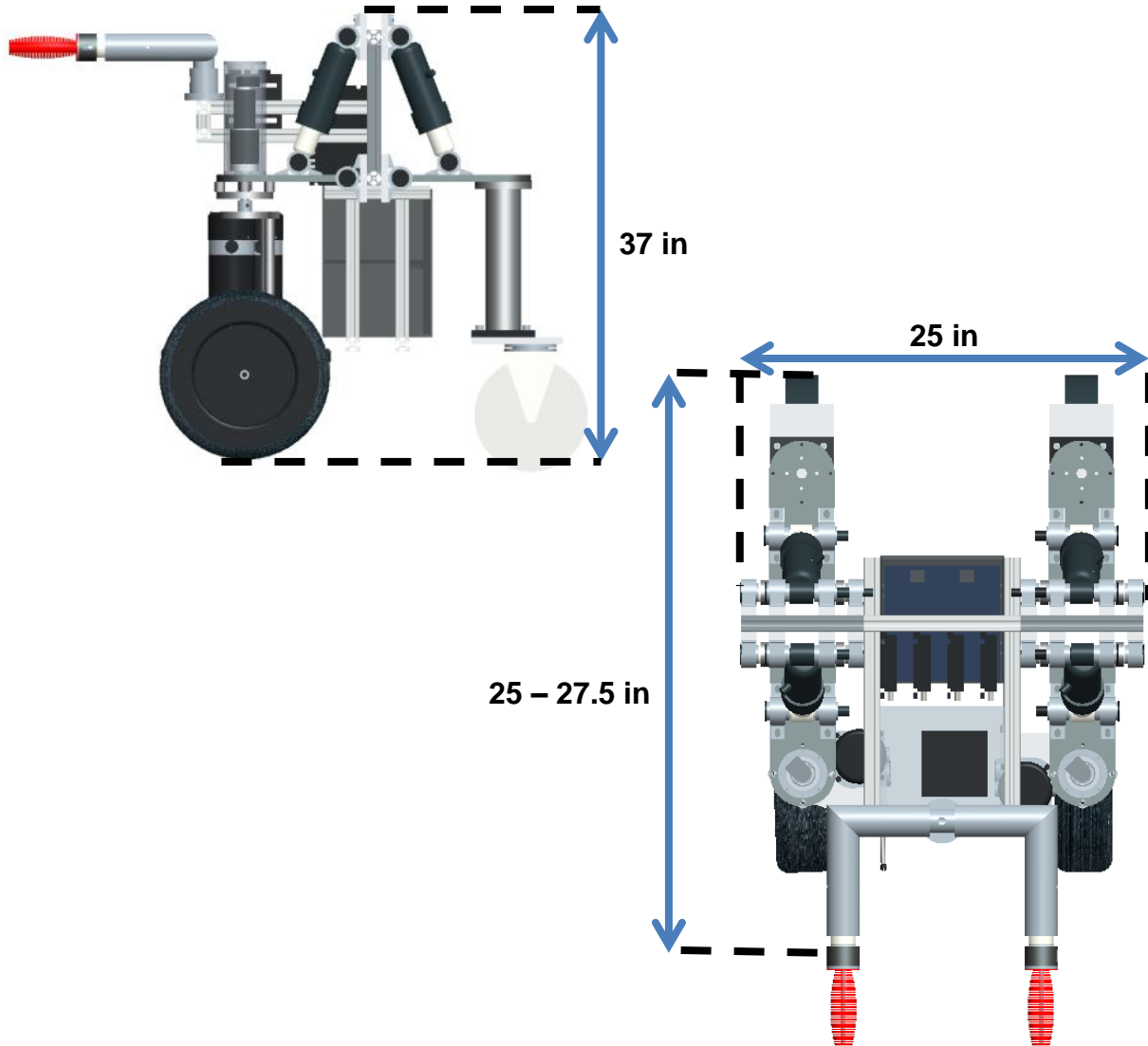

Dimensions:

- Length: 25 – 27.5
- Width: 25 in
- Height: 37 in
- Weight: ~180 lbs

Decision Matrix Comparison

| | Initial 1 | | | Initial 2 | | Initial 3 | | Initial 4 | | Initial 5 | |
|-------------------|-----------|-------|----------|-----------|----------|-----------|----------|-----------|----------|-----------|----------|
| | Weight | Score | Weighted | Score | Weighted | Score | Weighted | Score | Weighted | Score | Weighted |
| Versatility | 0.15 | 3 | 0.454 | 5 | 0.757 | 3 | 0.454 | 3 | 0.454 | 3 | 0.454 |
| Robustness | 0.17 | 4 | 0.699 | 3 | 0.524 | 5 | 0.874 | 3 | 0.524 | 4 | 0.699 |
| User-friendliness | 0.22 | 3 | 0.670 | 4 | 0.894 | 2 | 0.447 | 5 | 1.117 | 3 | 0.670 |
| Cost | 0.04 | 2 | 0.086 | 2 | 0.086 | 1 | 0.043 | 1 | 0.043 | 1 | 0.043 |
| Indoor | 0.14 | 3 | 0.429 | 3 | 0.429 | 2 | 0.286 | 3 | 0.429 | 1 | 0.143 |
| Outdoor | 0.23 | 4 | 0.926 | 3 | 0.695 | 3 | 0.695 | 2 | 0.463 | 5 | 1.158 |
| Weight | 0.03 | 2 | 0.066 | 3 | 0.099 | 1 | 0.033 | 4 | 0.132 | 1 | 0.033 |
| | | Sum | 3.331 | | 3.483 | | 2.832 | | 3.163 | | 3.200 |

| | Interim 1 | | | Interim 2 | | Interim 3 | | Final | |
|-------------------|-----------|-------|----------|-----------|----------|-----------|----------|-------|----------|
| | Weight | Score | Weighted | Score | Weighted | Score | Weighted | Score | Weighted |
| Versatility | 0.15 | 4 | 0.606 | 4 | 0.606 | 4 | 0.606 | 4 | 0.606 |
| Robustness | 0.17 | 3 | 0.524 | 3 | 0.524 | 2 | 0.350 | 3 | 0.524 |
| User-friendliness | 0.22 | 3 | 0.670 | 4 | 0.894 | 5 | 1.117 | 5 | 1.117 |
| Cost | 0.04 | 2 | 0.086 | 2 | 0.086 | 4 | 0.171 | 3 | 0.128 |
| Indoor | 0.14 | 2 | 0.286 | 2 | 0.286 | 5 | 0.715 | 5 | 0.715 |
| Outdoor | 0.23 | 5 | 1.158 | 5 | 1.158 | 3 | 0.695 | 4 | 0.926 |
| Weight | 0.03 | 2 | 0.066 | 2 | 0.066 | 3 | 0.099 | 2 | 0.066 |
| | | | 3.396 | | 3.619 | | 3.752 | | 4.083 |

- 1) Project Introduction**
- 2) Design Specifications**
- 3) Concept Generation**
- 4) Interim Designs**
- 5) Final Design**
- 6) Manufacturing & Assembly**
- 7) Testing & Results**
- 8) Discussion & Conclusions**

Manufacturing & Assembly

1. Frame
2. Suspension
3. Leg assemblies
4. Motor mounts
5. Handles

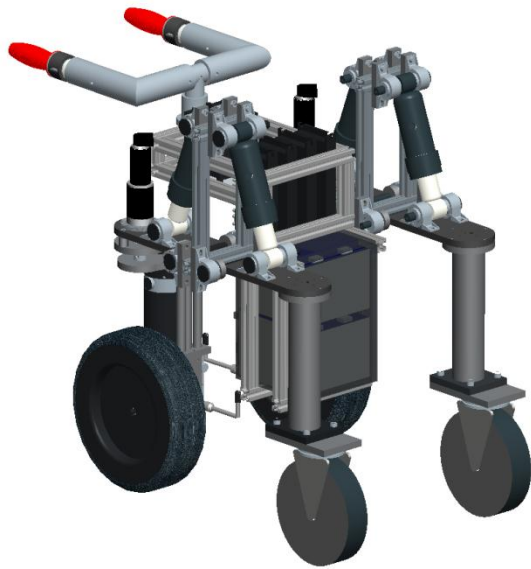

CAD of final design

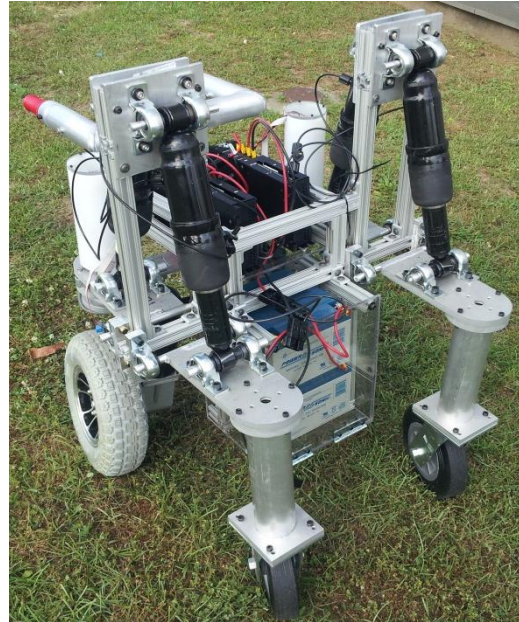
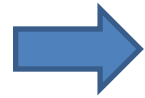

Final assembly

Manufacturing & Assembly

extra support

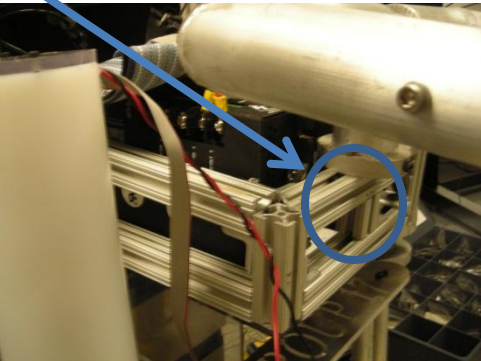
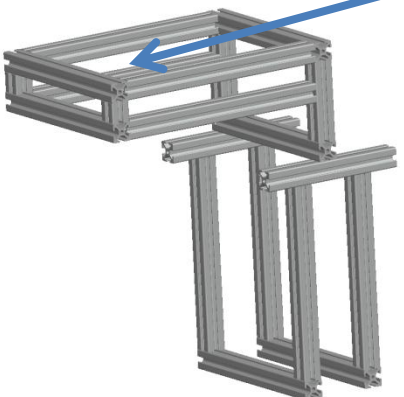

Close up of handle frame

extended plate

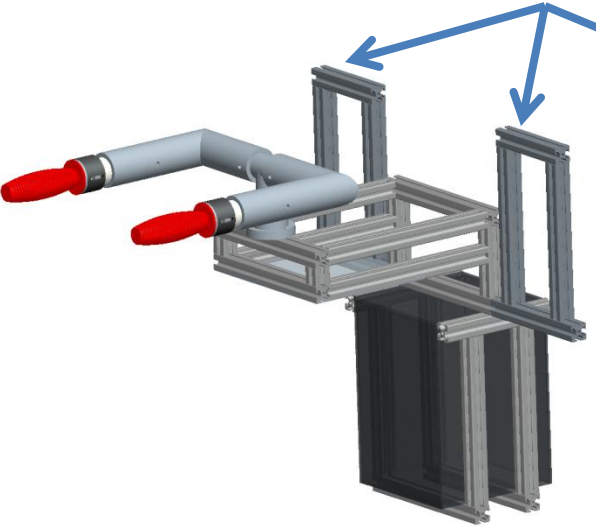

CAD of final frame design

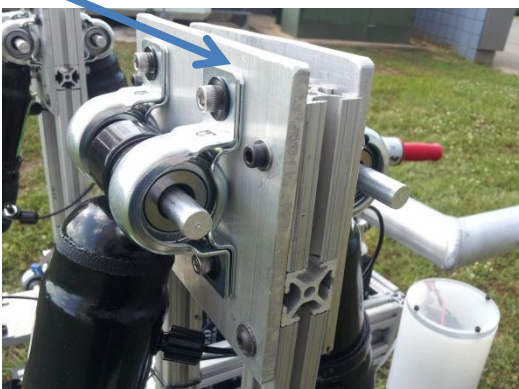

Close up of suspension mount

1. Frame

Modifications:

- Additional supports to prevent bending moment
- Extended plates for suspension mounting

Manufacturing & Assembly

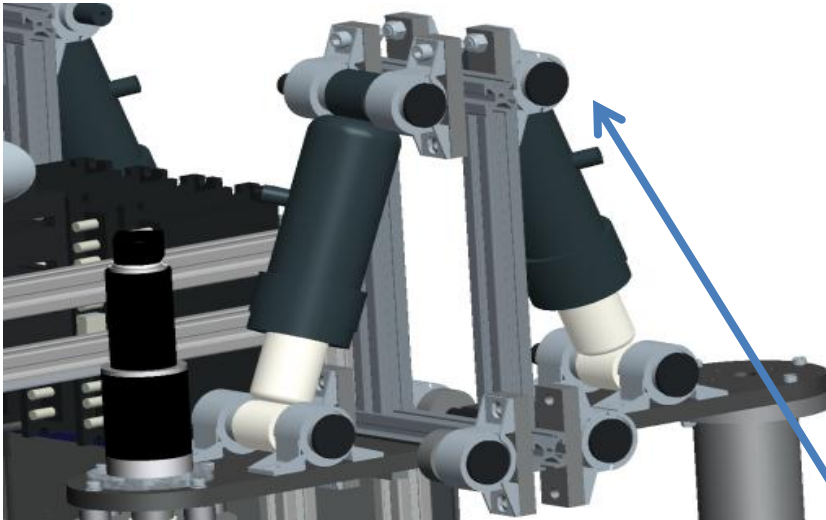

CAD of final suspension design

higher mount

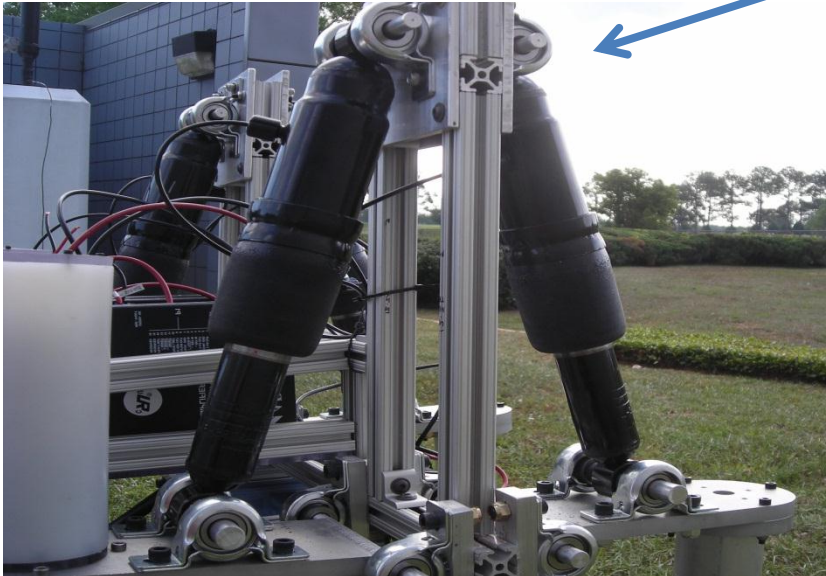

Suspension assembly

2. Suspension

Modifications:

- Higher mounting location

Manufacturing & Assembly

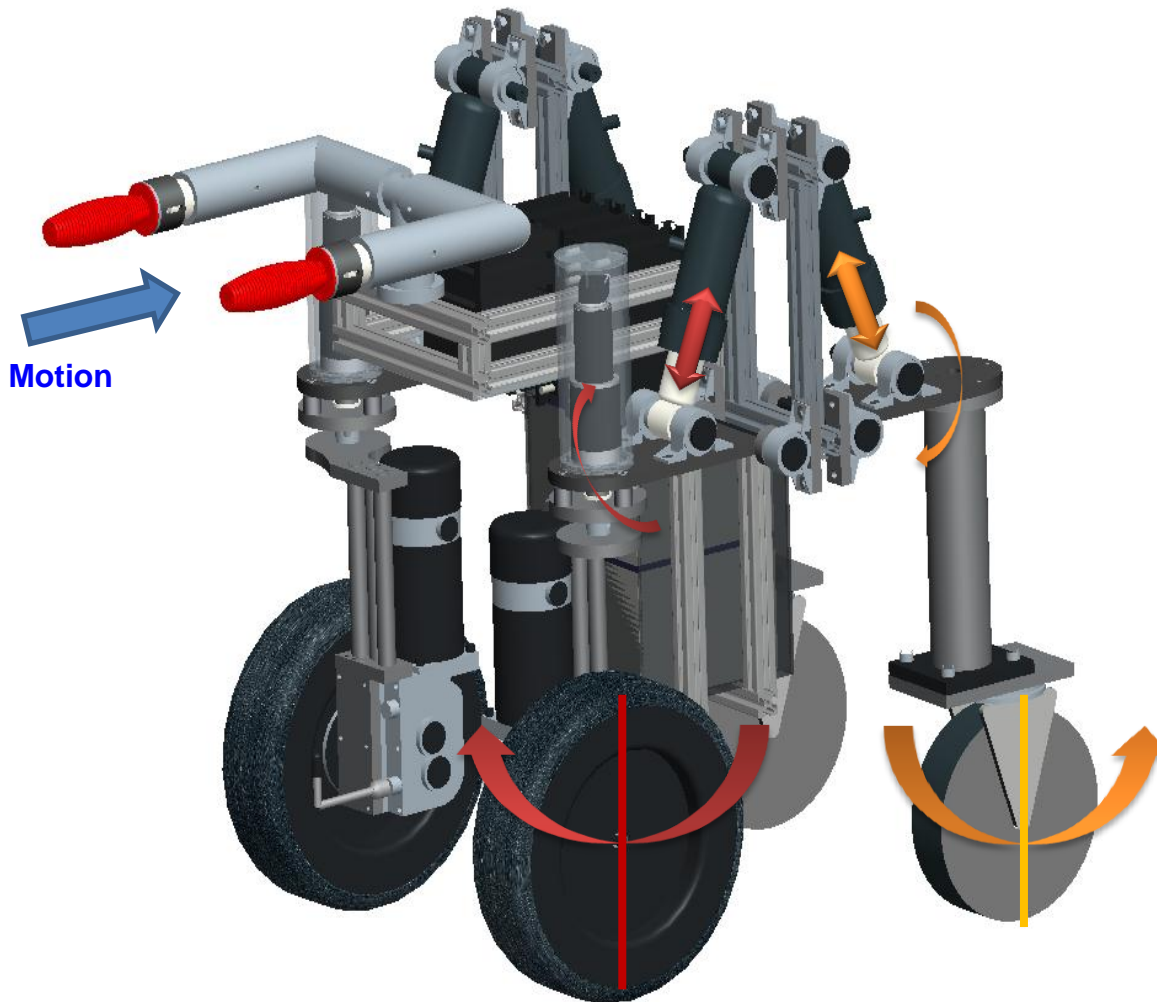

Suspension movement diagram

2. Suspension

Modifications:

- Higher mounting location

Manufacturing & Assembly

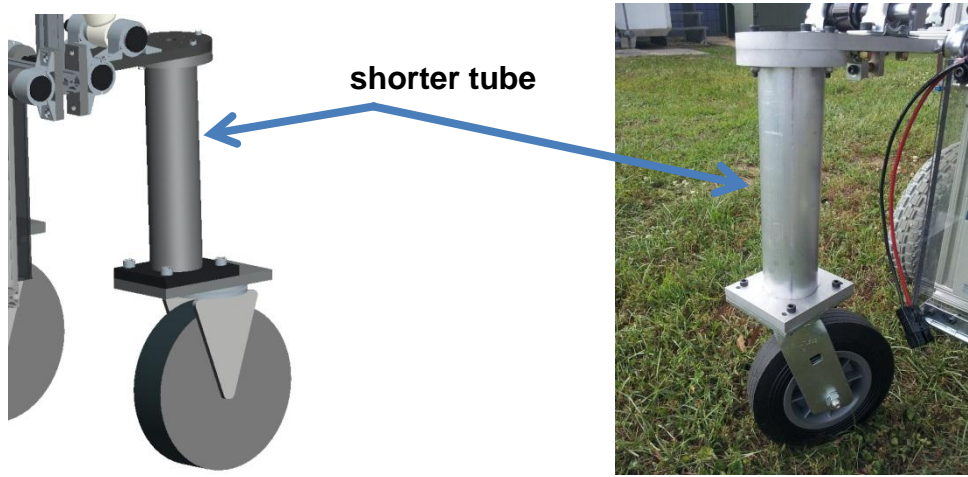

CAD of final caster wheel design

Caster wheel assembly

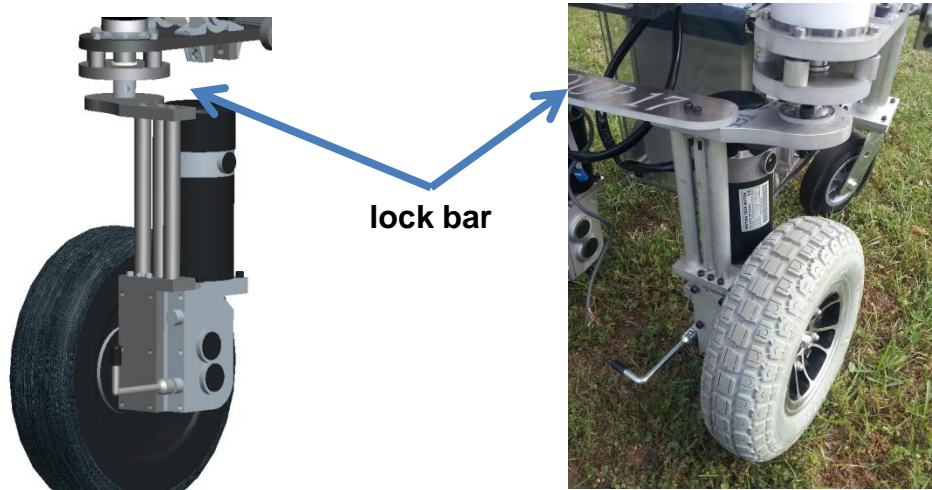

CAD of final driving wheel design

Driving wheel assembly

3. Leg assemblies

Modifications:

- Slightly shorter aluminum tubing
- Lock bar
 - Passive
 - Reduced complexity

Manufacturing & Assembly

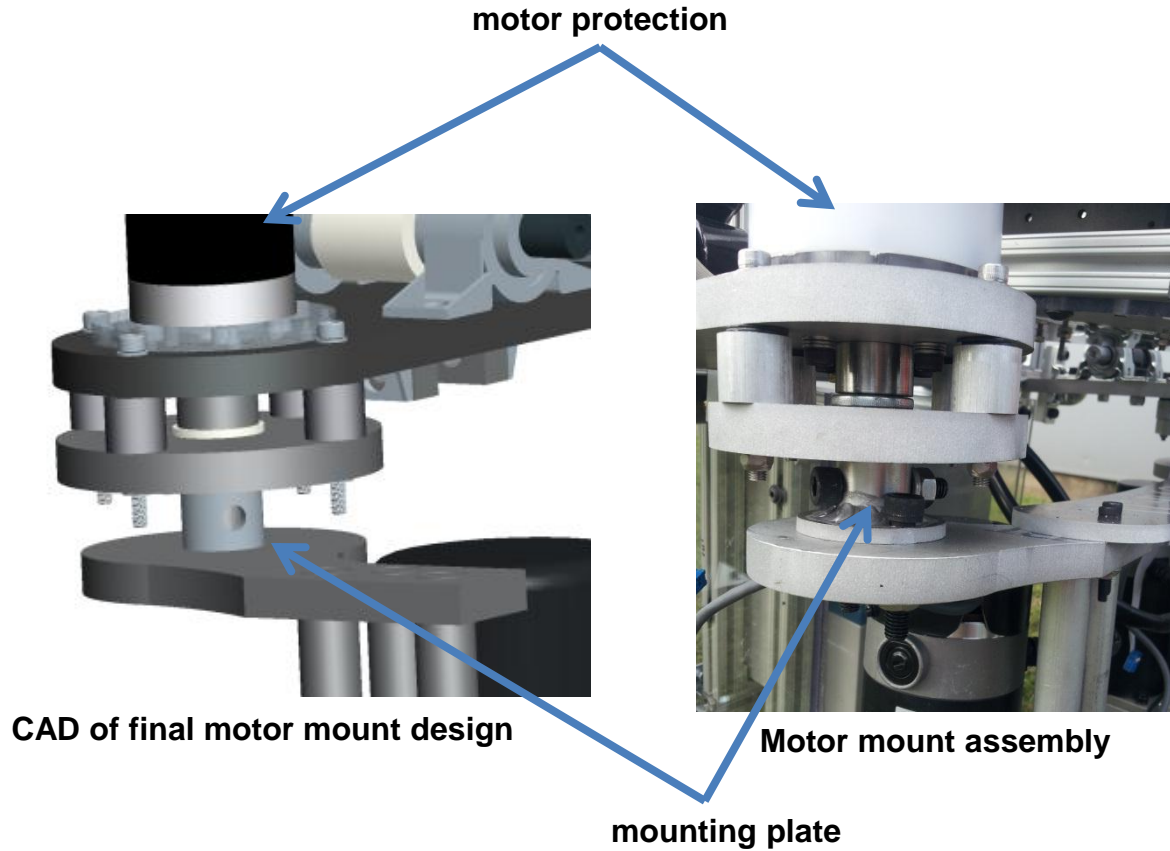

4. Motor mounts

Modifications:

- Steering motor protective cover
- Bolted mounting plate

Manufacturing & Assembly

5. Handles

Modifications:

- Modified potentiometer housing

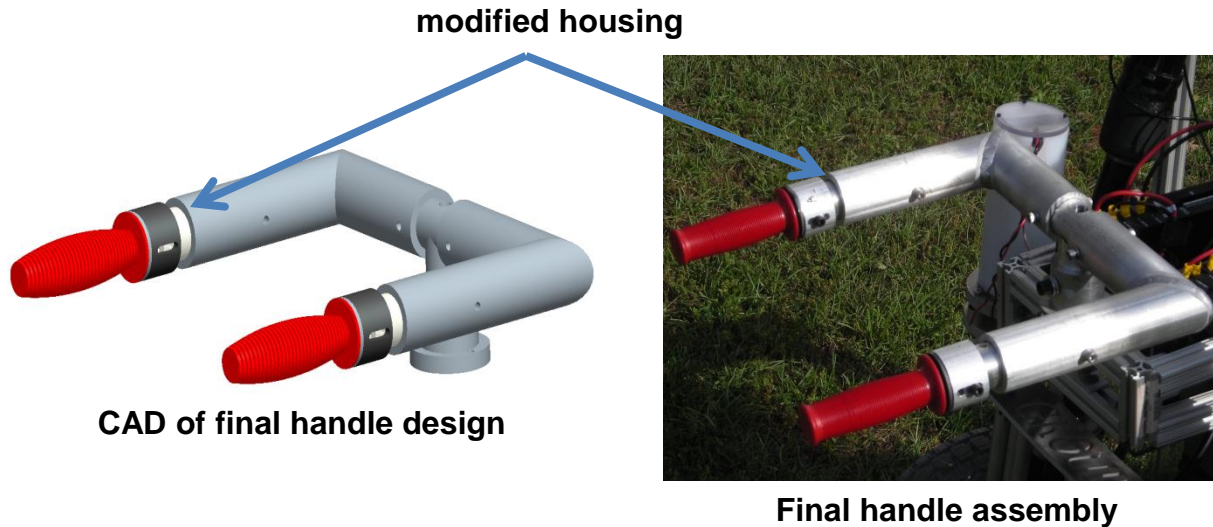

- 1) Project Introduction**
- 2) Design Specifications**
- 3) Concept Generation**
- 4) Interim Designs**
- 5) Final Design**
- 6) Manufacturing & Assembly**
- 7) Testing & Results**
- 8) Discussion & Conclusions**

Initial Tests

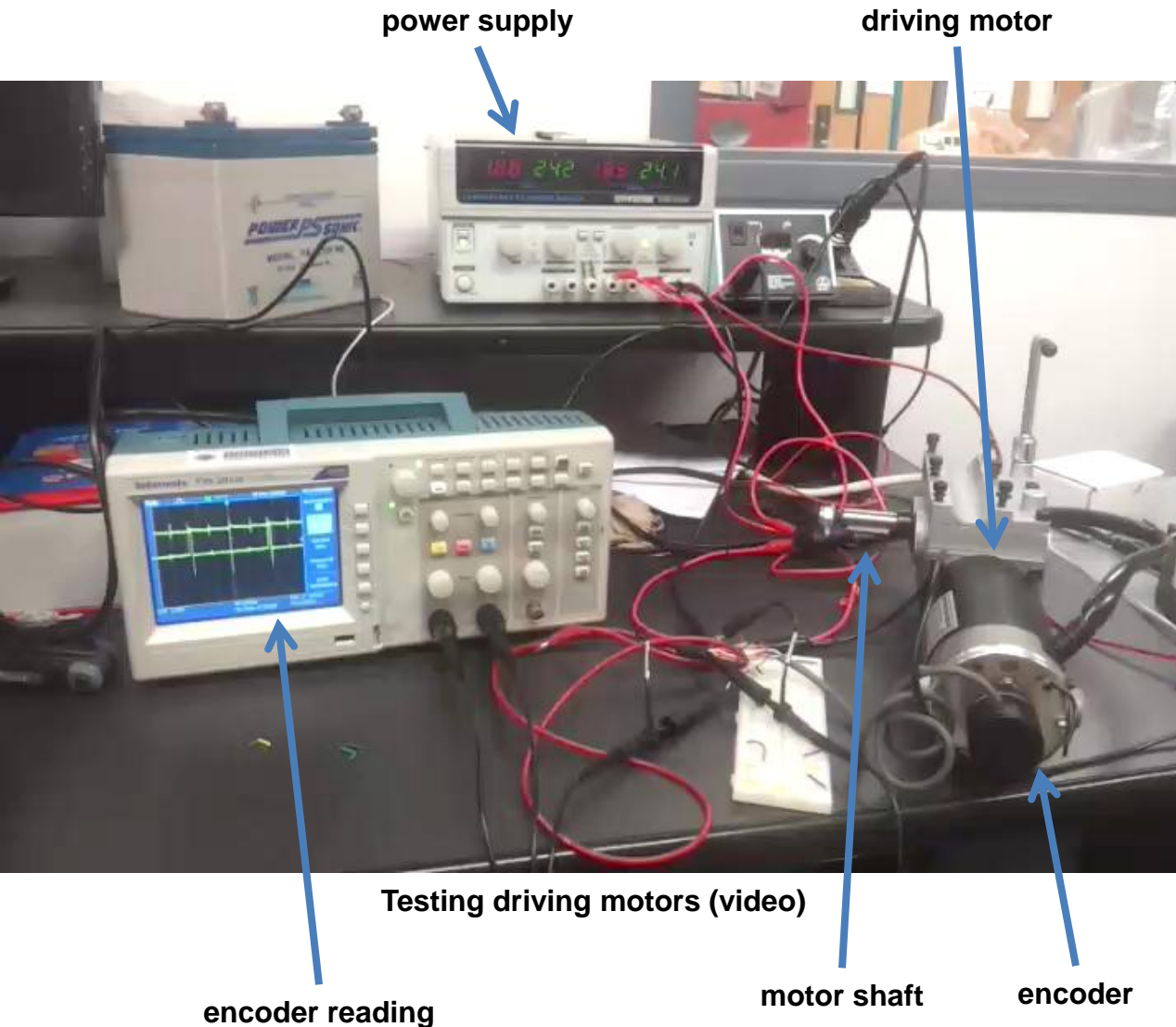

1. Driving Motors

Initial Tests

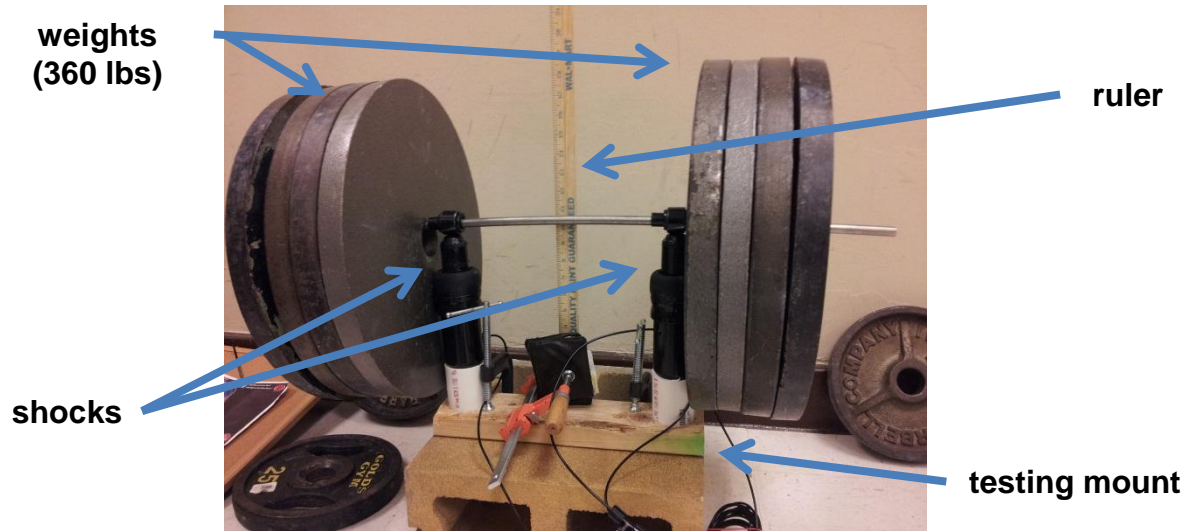

Picture of testing setup

Air Shock Compression at various Loading and Pressures

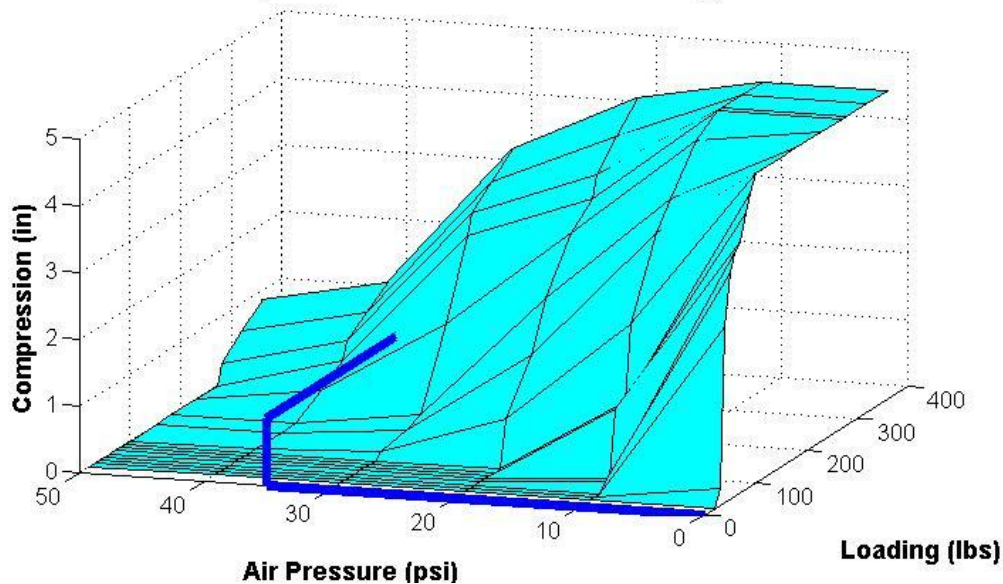

1. Driving Motors

2. Air shocks

Example Specifications:

- 35 psi
- 1.5 in compression
- 150 lbs

Initial Tests

multi-meter

potentiometer

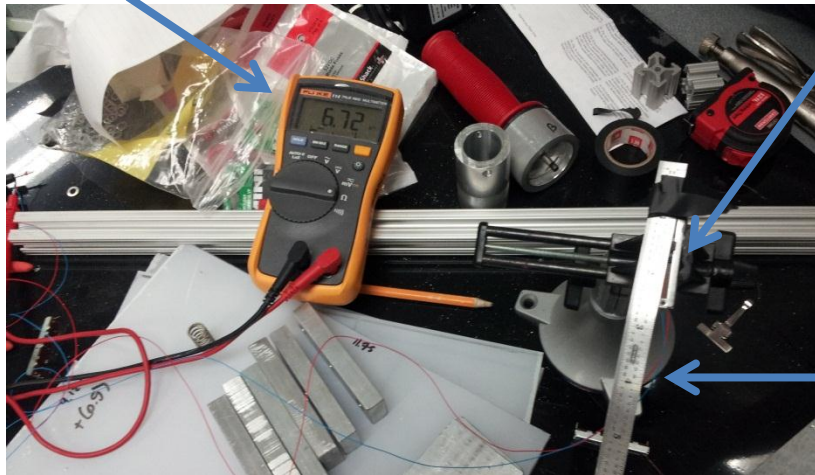

ruler

Picture of testing setup

Linear Resistance of Potentiometers

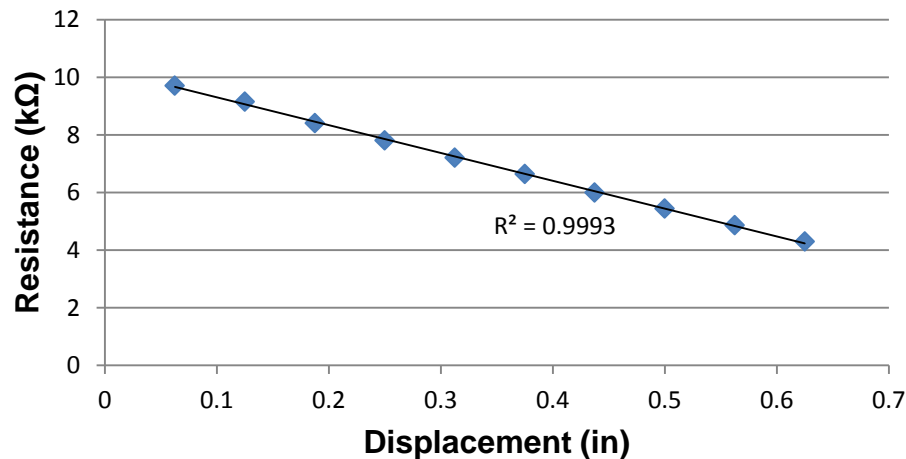

1. Driving Motors

2. Air shocks

3. Linear potentiometers

Initial Tests

potentiometer

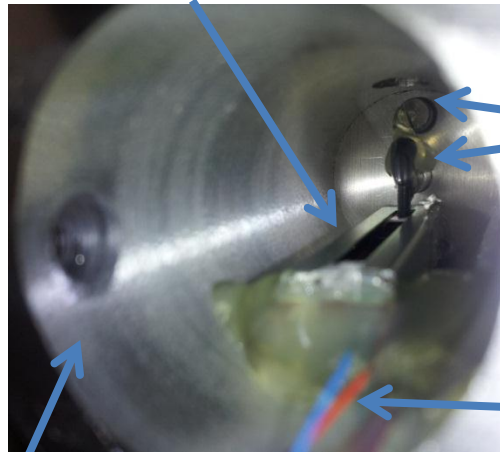

alignment shafts

wires

Mounting potentiometer

aluminum tube



Mounted potentiometer displacement response (video)

1. Driving Motors

2. Air shocks

3. Linear potentiometers

Design Tests

air shocks

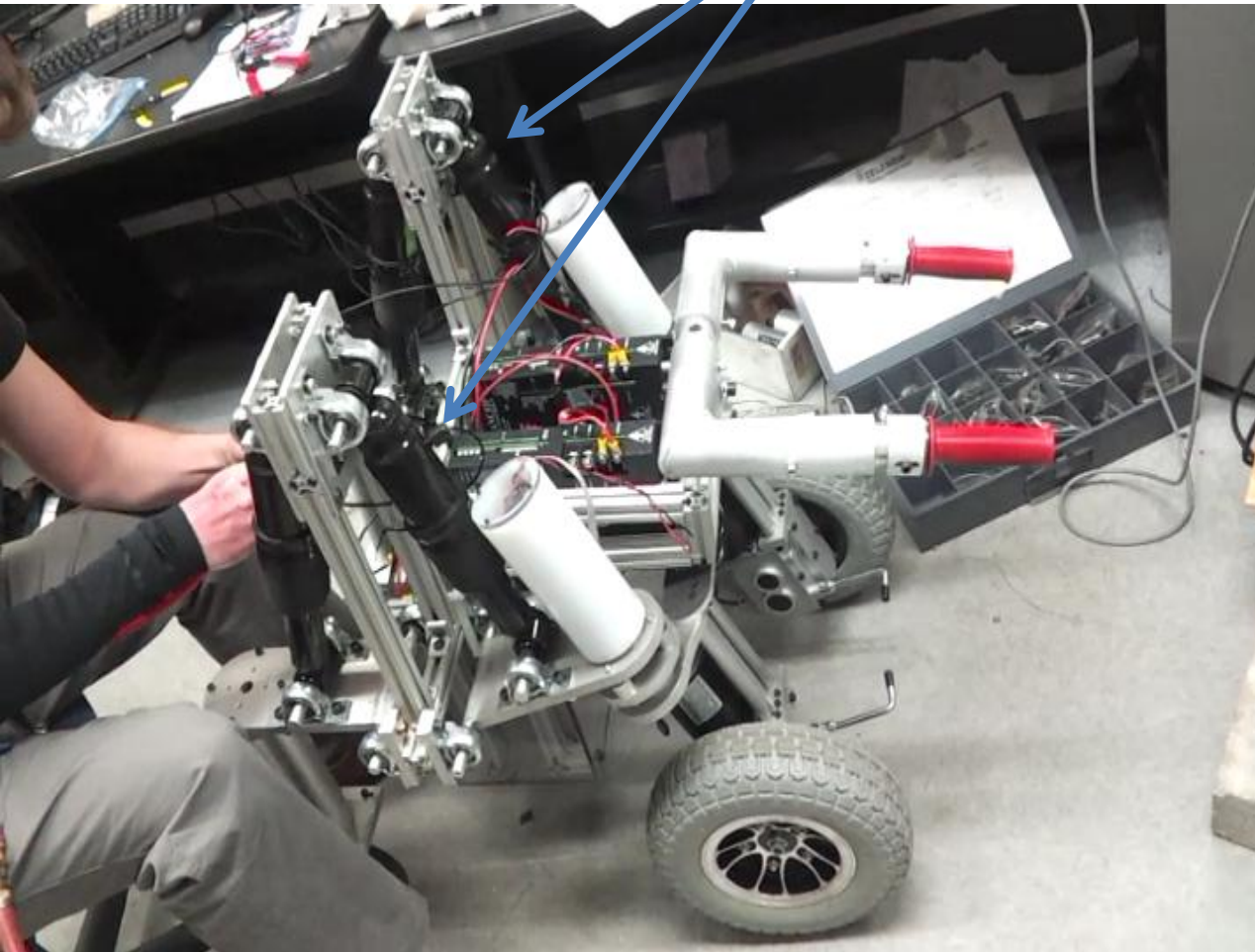

1. Air Shocks

Testing air shocks (video)

Design Tests

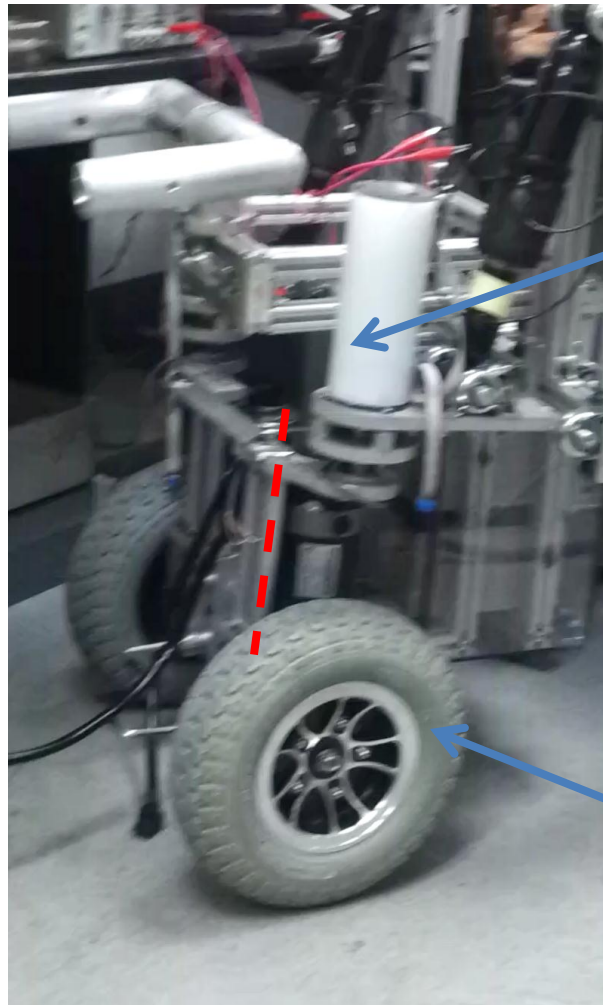

Testing steering motors (video)

1. Air Shocks

2. Steering Motors

Design Tests

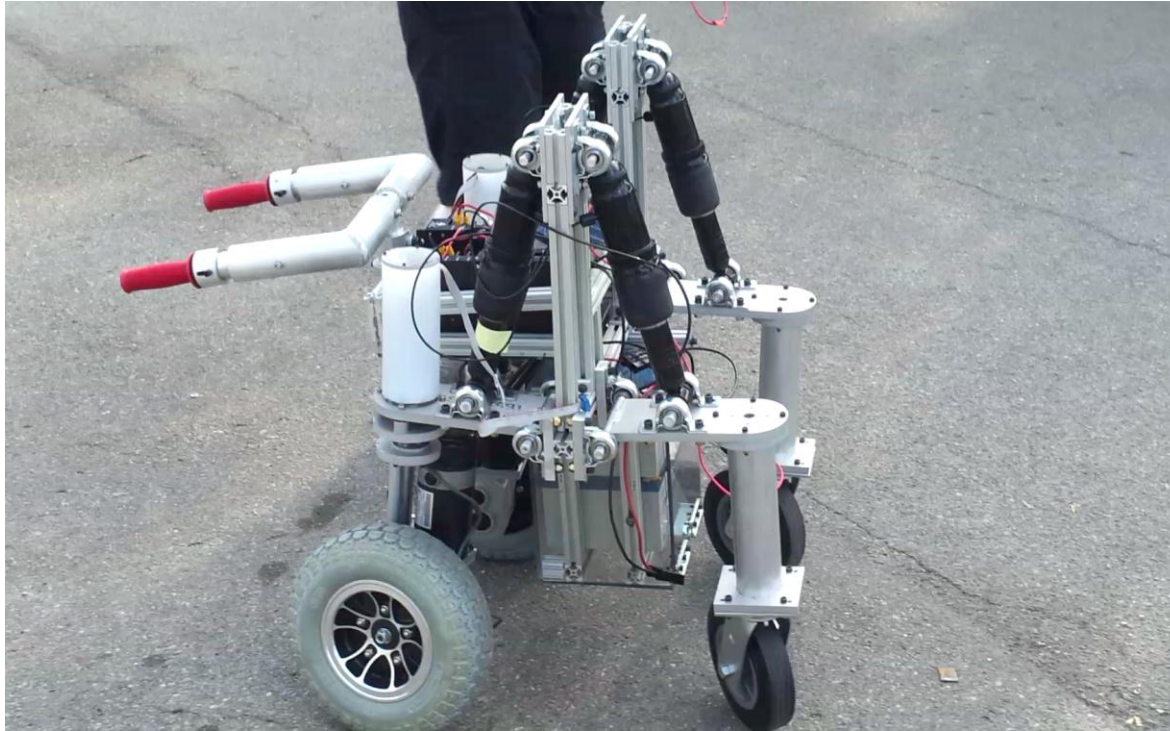

Testing driving motors (video)

- 1. Air Shocks**
- 2. Steering Motors**
- 3. Driving Motors**

Design Tests



Tile, carpet, cement, grass (video)



Gravel (video)

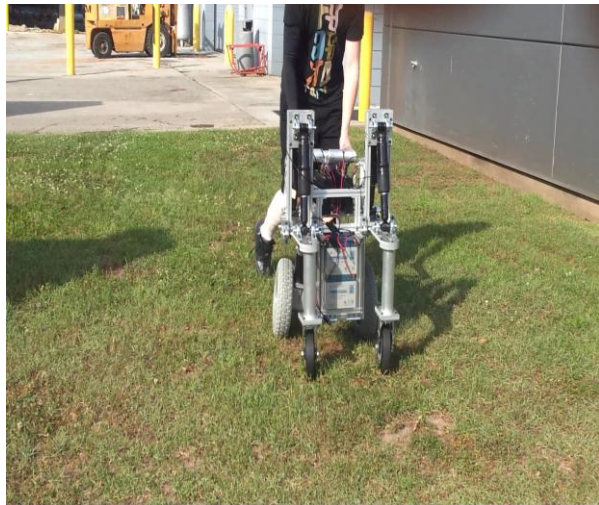

Large obstacles (video)



Ramps (video)

1. Air Shocks

2. Steering Motors

3. Driving Motors

4. Various Surfaces

- Pushing

Design Tests



Grass, cement (video)

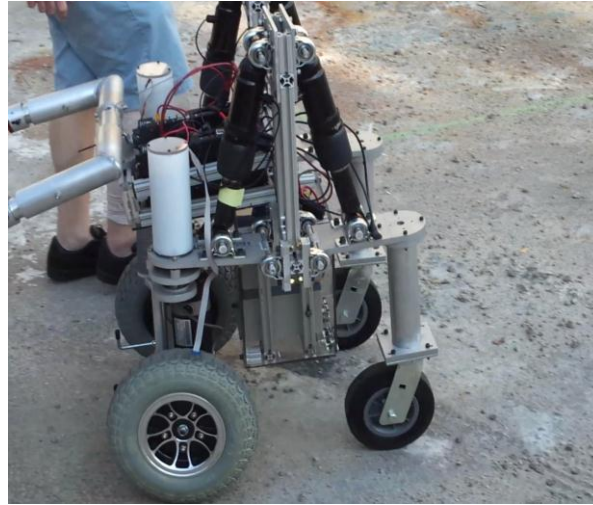

Gravel (video)



Tile (video)



Slopes (video)

1. Air Shocks
2. Steering Motors
3. Driving Motors
4. Various Surfaces
 - Pushing
 - Driving

Results Summary

Completed Objectives:

- **Construct stable walker**
 - **Passive / Active**
- **Operate within ADA standard environments**
 - **Width less than 32 inch**
 - **Weight less than 200 lbs**
- **Traverse varied terrain**
 - **Indoor: Tile, Carpet**
 - **Outdoor: Concrete, Grass, Gravel, Dirt, Slopes**
- **Incorporate operational power systems**
 - **Driving motors**
 - **Steering motors**
 - **Potentiometers**



Results Summary

Remaining Tasks:

- **Recalibrate shocks**
 - Experimentally or empirically
- **Stabilize / finalize handles**
 - More mounting holes
 - Finish machining height inserts
- **Reinforce structure**
 - Connection braces
 - Locking washers to counteract vibrations
- **Incorporate control system**
 - Program microcontroller
 - Test / debug
- **Continue testing**
 - Obstacle traversing
 - Loading



- 1) Project Introduction**
- 2) Design Specifications**
- 3) Concept Generation**
- 4) Interim Designs**
- 5) Final Design**
- 6) Manufacturing & Assembly**
- 7) Testing & Results**
- 8) Discussion & Conclusions**

Project Budget

Budget Allowance

\$5,000.00

Total Money Spent as of 4/12/2012

\$4,513.35

Available funds as of 4/12/2012

\$486.65

Expenditures:

- **Motors: \$1900**
- **Hardware: \$1500**
- **Electronics: \$800**
- **Miscellaneous: \$300**

Provided:

- **Machine Shop: 75+ hrs**
- **Motor drivers: \$2900**
- **Computer: \$1000**
- **Encoders: \$700**
- **Raw Material: \$500**
- **Miscellaneous: \$100**

Economics

Potential Markets:

- Medical field
 - Hospitals
 - Rehabilitation Centers
- Direct to consumer
 - Elderly
 - Disabled

Estimated Costs:

- Motors: \$2000
- Controls: \$2000
- Hardware: \$1000
- Total: \$5000

Standard power chair: \$5000



<http://www.case.edu/think/breakingnews/careproject.html>



<http://www.flickr.com/photos/chrisgold/6435078007/lightbox/>

Health & Safety

Immediate Safety Concerns:

- **Hardware**
 - Sharp edges / corners
 - Heavy
- **Electronics**
 - High voltage
 - Exposed wires

Consumer Safety Concerns:

- **Run-away hazard**
 - Kill switch
- **Shocking hazard**
 - Not waterproof
- **Falling hazard**
 - Heavy



http://en.wikipedia.org/wiki/File:Caution_sign_used_on_roads_pn.svg

Summary

Problem:

- Elderly & disabled utilizing current generation assistive devices are limited in their outdoor mobility

Solution:

- Develop robotic outdoor walker to improve mobility and quality of assistance provided



Glasshouse Images ©

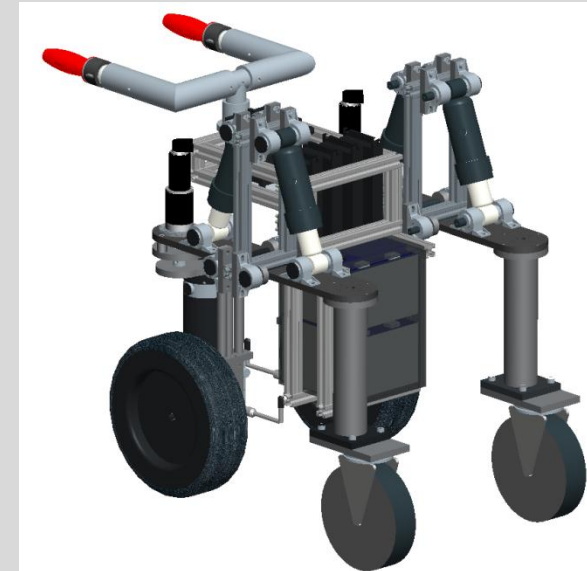

Summary

Objectives:

- Traverse varied terrain
- Scale 4 inch obstacles
- Operate within ADA standards
- Easily adaptable into future work

Results:

- Successful passive & non-controlled active prototype with appropriate dimensions
- Reinforcement to frame & slight modifications to suspension may improve performance
- Larger casters & more even weight distribution may improve obstacle scaling
- Further tests required on slopes & in loading

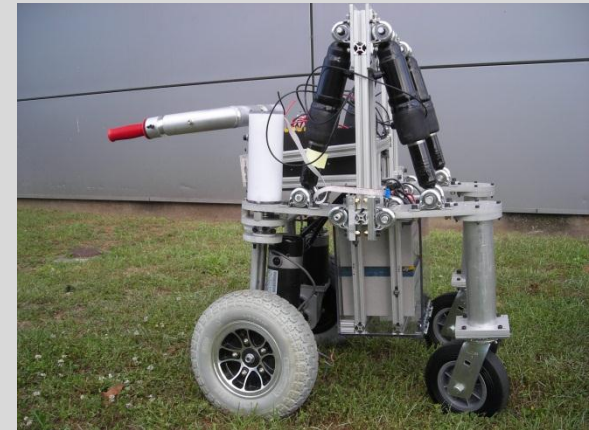
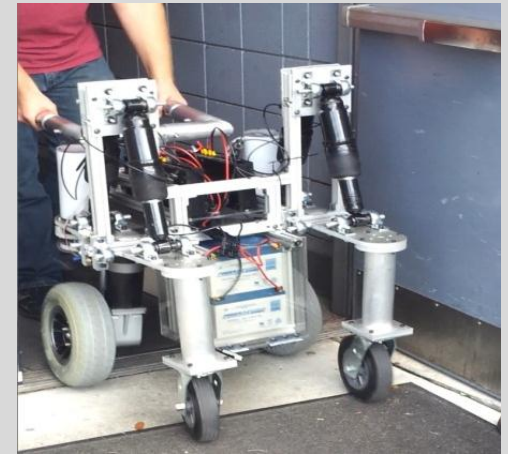

References

http://en.wikipedia.org/wiki/File:Caution_sign_used_on_roads_pn.svg
<http://www.flickr.com/photos/chrisgold/6435078007/lightbox/>
<http://www.case.edu/think/breakingnews/careproject.html>
<http://www.nashuatelegraph.com/sportslocalsports/954816-222/art-demers-focusing-on-return-to-classroom.html#>
<http://thesnowangels.org/>
<http://hic2011.edublogs.org/2011/10/20/green/>
<http://topnews.net.nz/content/211444-7000-red-cross-volunteers-put-100-worth-free-labour-each>
<http://www.access-board.gov/adaag/html/>
<http://www.a-m-c.com/images/productpics/120a10.jpg>
http://www.easycomforts.com/EasyComforts/subcategory.aspx?id=mobility%20and%20accessories&bid=EC_Flash2^Mobility%20and%20Accessories
<http://www.4-medical-supplies.com/electric-power-wheelchairs/>
<http://www.assistivedeviceskey.com/category/2185098>
<http://www.rimdoor.com/page.cfm?page=140>
http://hungyulin.com/?page_id=5
<http://www.hizook.com/blog/2009/08/10/robotic-walkers-assist-elderly>
http://news.cnet.com/8301-13639_3-10098240-42.html
http://www.robotcombat.com/store_tanktreads.html
<http://www.directindustry.com/prod/kistler/force-plates-5346-40016.html>
<http://dcacmotors.blogspot.com/2009/08/dc-motors-torquespeed-curves.html>
http://en.wikipedia.org/wiki/File:Mass_spring_damper.png
<http://www.superstock.com/resultsframe.asp>

Questions?